

MOUNTING AND OPERATING INSTRUCTIONS



EB 2186 EN

Translation of original instructions



Series 43 Temperature Regulators Type 43-2 N

Edition July 2024



Note on these mounting and operating instructions

These mounting and operating instructions assist you in mounting and operating the device safely. The instructions are binding for handling SAMSON devices. The images shown in these instructions are for illustration purposes only. The actual product may vary.

- For the safe and proper use of these instructions, read them carefully and keep them for later reference.
- If you have any questions about these instructions, contact SAMSON's After-sales Service (aftersaleservice@samsongroup.com).



Documents relating to the device, such as the mounting and operating instructions, are available on our website at www.samsongroup.com > **Downloads > Documentation.**

Definition of signal words

DANGER

Hazardous situations which, if not avoided, will result in death or serious injury

WARNING

Hazardous situations which, if not avoided, could result in death or serious injury

NOTICE

Property damage message or malfunction

Note

Additional information

Tip

Recommended action

1	Safety instructions and measures	5
1.1	Notes on possible severe personal injury	8
1.2	Notes on possible personal injury	8
1.3	Notes on possible property damage	9
2	Markings on the device	11
2.1	Inscription on the control thermostat	11
2.2	Inscription on the valve	11
3	Design and principle of operation	12
3.1	Temperature regulator	12
3.1.1	Version with double adapter and/or manual adjuster	12
2.3	Location of the inscriptions on the valve and control thermostat	12
2.4	Material identification number	12
3.2	Technical data	14
3.3	Process medium and scope of application	14
4	Measures for preparation	17
4.1	Unpacking	17
4.2	Transporting and lifting	17
4.3	Storage	17
4.4	Preparation for installation	18
5	Mounting and start-up	18
5.1	Mounting the control thermostat onto the valve	18
5.2	Additional fittings	19
5.3	Installing the valve into the pipeline	20
5.3.1	Installation conditions	20
5.3.2	Installing the temperature sensor	20
5.4	Start-up	21
6	Operation	22
6.1	Adjusting the temperature	22
6.2	Servicing	23
6.3	Preparation for return shipment	23
7	Malfunctions	24
8	Decommissioning and removal	24
8.1	Decommissioning	26
8.2	Disposal	26

Contents

9	Appendix.....	27
9.1	After-sales service and spare parts	27
9.2	Tightening torques.....	27
10	Certificates	27

1 Safety instructions and measures

Intended use

The Type 43-2 N Temperature Regulator is designed for temperature control of the energy supply to heat generators (e.g. heat exchangers) by closing the valve.

The devices are designed to operate under exactly defined conditions (e.g. operating pressure, process medium, temperature). Therefore, operators must ensure that the devices are only used in operating conditions that meet the specifications used for sizing the devices at the ordering stage. In case operators intend to use the devices in applications or conditions other than those specified, contact SAMSON.

SAMSON does not assume any liability for damage resulting from the failure to use the device for its intended purpose or for damage caused by external forces or any other external factors.

→ Refer to the technical data and inscription on the device for limits and fields of application as well as possible uses.

Reasonably foreseeable misuse

The devices are not suitable for use outside the limits defined during configuration and by the technical data. Furthermore, the following activities do not comply with the intended use:

- Use of non-original spare parts
- Performing service and repair work not described

Qualifications of operating personnel

The devices must be mounted, started up, serviced and repaired by fully trained and qualified personnel only; the accepted industry codes and practices are to be observed. According to these mounting and operating instructions, trained personnel refers to individuals who are able to judge the work they are assigned to and recognize possible hazards due to their specialized training, their knowledge and experience as well as their knowledge of the applicable standards.

Revisions and other modifications

Revisions, conversions or other modifications of the product are not authorized by SAMSON. They are performed at the user's own risk and may lead to safety hazards, for example. Furthermore, the product may no longer meet the requirements for its intended use.

Safety instructions and measures

Personal protective equipment

SAMSON recommends checking the hazards posed by the process medium being used (e.g. ► GESTIS (CLP) hazardous substances database).

- ➔ Provide protective equipment (e.g. safety gloves, eye protection) appropriate for the process medium used.
- ➔ Wear hearing protection when working near the valve. Follow the instructions given by the plant operator.
- ➔ Check with the plant operator for details on further protective equipment.

Warning against residual hazards

To avoid personal injury or property damage, plant operators and operating personnel must prevent hazards that could be caused in the regulator by the process medium, the operating pressure or by moving parts by taking appropriate precautions. Plant operators and operating personnel must observe all hazard statements, warnings and caution notes in these mounting and operating instructions.

Hazards resulting from the special working conditions at the installation site of the regulator must be identified in a risk assessment and prevented through the corresponding safety instructions drawn up by the operator.

SAMSON also recommends checking the hazards posed by the process medium being used (e.g. ► GESTIS (CLP) hazardous substances database).

- ➔ Observe safety measures for handling the device as well as fire prevention and explosion protection measures.

These mounting and operating instructions deal with the standard version of the device. Components of the device that differ to those used for the standard version described in this document can be exchanged with other certain SAMSON components. The residual hazards of these components are described in the associated mounting and operating instructions (see 'Referenced documents' chapter).

Responsibilities of the operator

Operators are responsible for proper use and compliance with the safety regulations.

Operators are obliged to provide these mounting and operating instructions as well as the referenced documents to the operating personnel and to instruct them in proper operation. Furthermore, operators must ensure that operating personnel or third parties are not exposed to any danger.

Operators are additionally responsible for ensuring that the limits for the product defined in the technical data are observed. This also applies to the start-up and shutdown procedures. Start-up and shutdown procedures fall within the scope of the operator's duties and, as such, are not part of these mounting and operating instructions. SAMSON is unable to make any statements about these procedures since the operative details (e.g. differential pressures and temperatures) vary in each individual case and are only known to the operator.

Responsibilities of operating personnel

Operating personnel must read and understand these mounting and operating instructions as well as the referenced documents and observe the specified hazard statements, warnings and caution notes. Furthermore, operating personnel must be familiar with the applicable health, safety and accident prevention regulations and comply with them.

Referenced standards, directives and regulations

The devices comply with the requirements of the European Pressure Equipment Directive 2014/68/EU. Devices with a CE marking have an EU declaration of conformity, which includes information about the applied conformity assessment procedure. This EU declaration of conformity is included in the Appendix of these instructions (see Chapter 10).

Non-electric valve versions whose bodies are not lined with an insulating material coating do not have their own potential ignition source according to the hazard assessment stipulated in Clause 5.2 of ISO 80079-36, even in the rare incident of an operating fault. Therefore, such valve versions do not fall within the scope of Directive 2014/34/EU.

→ For connection to the equipotential bonding system, observe the requirements specified in Clause 6.4 of EN 60079-14 (VDE 0165-1).

Referenced documents

The following documents apply in addition to these mounting and operating instructions:

- Mounting and operating instructions for the control thermostats, e.g. ► EB 2430 and ► EB 2430-3
- Data sheet for double adapter Do3 and manual adjuster ► T 2176

1.1 Notes on possible severe personal injury

DANGER

Risk of bursting in pressure equipment.

Valves and pipelines are pressure equipment. Improper opening can lead to valve components bursting.

- Before starting any work on the valve, depressurize all plant sections affected as well as the valve.
- Drain the process medium from the plant sections affected as well as from the valve.
- Wear personal protective equipment.

1.2 Notes on possible personal injury

WARNING

Risk of personal injury due to residual process medium in the valve.

While working on the valve, residual process medium can escape and, depending on its properties, may lead to personal injury, e.g. burns.

- If possible, drain the process medium from the plant sections affected and from the valve.
- Wear protective clothing, safety gloves and eye protection.

Risk of burn injuries due to hot or cold components and pipelines.

Depending on the process medium, valve components and pipelines may get very hot or cold and cause burn injuries.

- Allow components and pipelines to cool down or warm up to the ambient temperature.
- Wear protective clothing and safety gloves.

⚠ WARNING**Damage to health relating to the REACH regulation.**

If a SAMSON device contains a substance listed as a substance of very high concern on the candidate list of the REACH regulation, this is indicated on the SAMSON delivery note.

- Information on the safe use of the part affected
 - ▶ www.samsongroup.com/en/about-samson/environment-social-governance/material-compliance/

1.3 Notes on possible property damage**⚠ NOTICE****Risk of irreparable regulator damage caused by the regulator components being taken apart.**

The thermostat, set point adjuster and capillary tube form an inseparable hydraulic unit. If these components are dismantled (e.g. removal of the capillary tube), the regulator will be irreparably damaged and will no longer be able to fulfill its monitoring and control task.

- Do not dismantle the regulator.
- Only perform allowed activities on the regulator.
- Contact SAMSON's After-sales Service before replacing spare parts.

Risk of valve damage due to contamination (e.g. solid particles) in the pipeline.

The plant operator is responsible for cleaning the pipelines in the plant.

- Flush the pipelines before start-up.
- Observe the maximum permissible pressure for valve and plant.

Risk of valve damage due to unsuitable medium properties.

The valve is designed for a process medium with defined properties.

- Only use the process medium specified for sizing the equipment.

NOTICE

Risk of leakage and valve damage due to over- or under-torquing.

Observe the specified torques when tightening valve components.

Excessive tightening torques lead to parts wearing out more quickly. Parts that are too loose may cause leakage.

→ Observe the specified tightening torques.

2 Markings on the device

There are several inscriptions on the device. The inscriptions are used to identify the separate regulator components (see Fig. 1 and Fig. 2).

The inscription shown was up to date at the time of publication of this document. The inscription on the device may differ from the one shown.

2.1 Inscription on the control thermostat

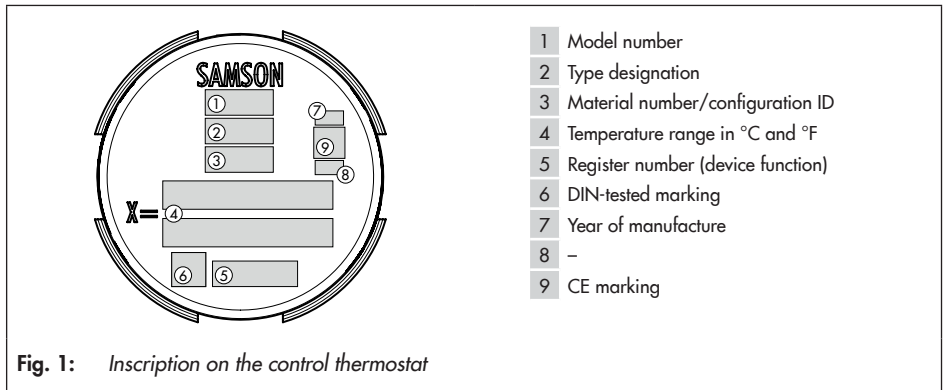

2.2 Inscription on the valve

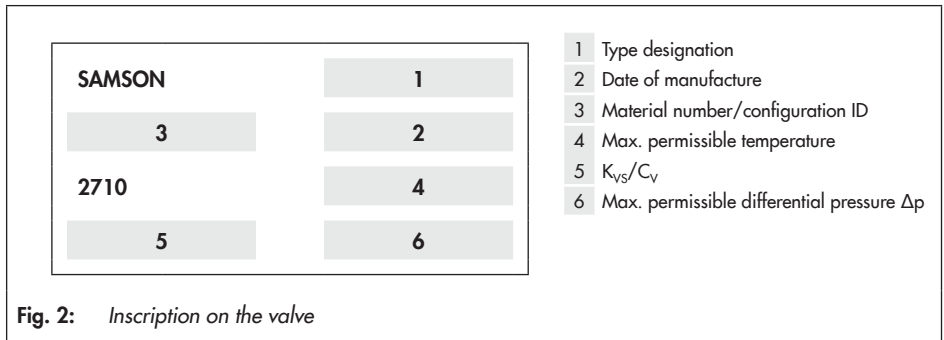

2.3 Location of the inscriptions on the valve and control thermostat

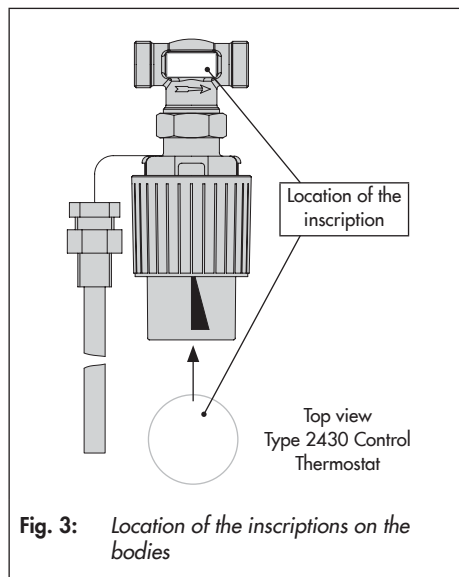

Fig. 3: Location of the inscriptions on the bodies

2.4 Material identification number

Specifying the configuration ID, you can contact us to find out which material is used. The configuration ID (3) is specified on the inscription.

For more details on the inscription (see Fig. 2 and Fig. 1).

3 Design and principle of operation

3.1 Temperature regulator

The temperature regulator consists of the Type 2432 Valve and the Type 2430 Thermostat attached to it.

The valve mainly consists of the valve body (1) with seat (2) and plug (3). The thermostat consists of the operating bellows (9), set point spring (7), capillary tube (10) and temperature sensor (16).

The valve is closed when the temperature reaches the adjusted set point.

3.1.1 Version with double adapter and/or manual adjuster

The temperature regulator can be equipped with a double adapter to connect an additional thermostat or manual adjuster to control a further control variable.

i Note

Accessories, such as the double adapter Do3 or manual adjuster, are described in

► T 2176.

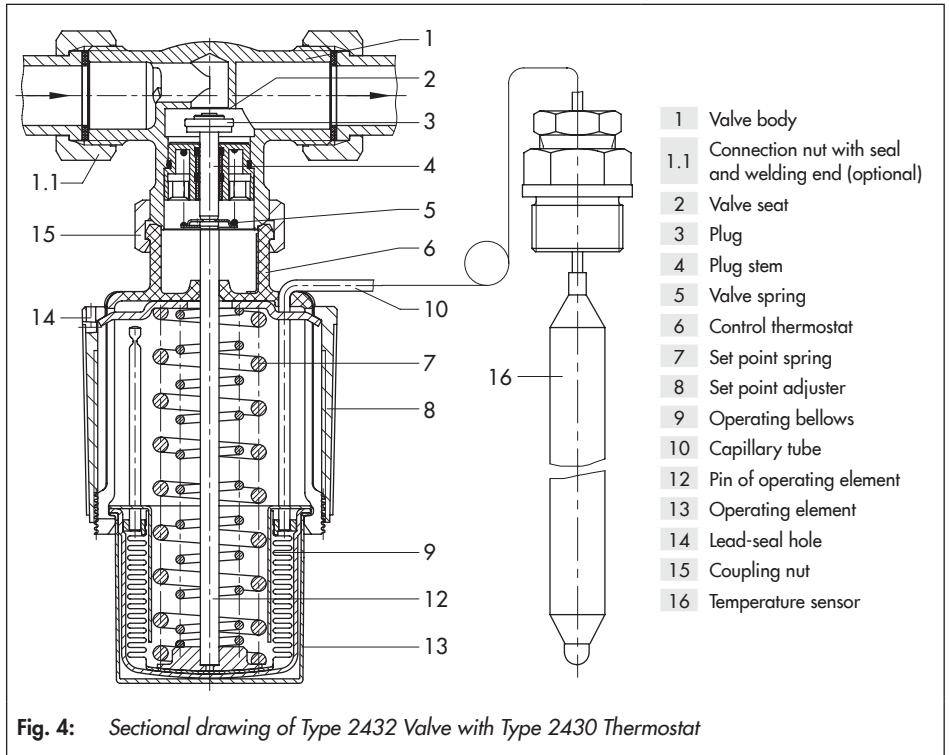

Fig. 4: Sectional drawing of Type 2432 Valve with Type 2430 Thermostat

Principle of operation:

The temperature regulator works according to the adsorption principle. The temperature of the medium creates a pressure in the temperature sensor (16) which is proportional to the measured temperature. This pressure is transferred through the capillary tube (10) to the operating bellows (9) and converted into a positioning force. The force is transferred over the pin (12) of the operating element to the plug stem (4) and plug (3). The position of the plug determines the flow rate of the

heat transfer medium across the area released between the valve seat (2) and plug. By turning the set point adjuster (8), the point of response is changed over the spring (7). As a result, the valve plug moves through its travel range within a higher or lower temperature range measured by the sensor.

i Note

Thermostats operating according to the vapor pressure principle are described in ► EB 2430-3.

3.2 Technical data

3.3 Process medium and scope of application

Temperature control of the energy supply to heat generators or heat exchangers by closing the valve. The temperature regulator is particularly suitable for local heat supply and large heating networks.

For set points from **0** to **100 °C** · Nominal size **DN 15** · **PN 16** · Max. **120 °C**

The Type 43-2 N Temperature Regulator operates without auxiliary energy.

i Note

Further details and technical data of the control thermostats and accessories are listed in the following mounting and operating instructions:

- Mounting and operating instructions for the control thermostats, e.g. ▶ EB 2430 and ▶ EB 2430-3
- Data sheet for double adapter Do3 and manual adjuster ▶ T 2176

Dimensions and weights

Table 3 provides a summary of the dimensions and weights. The lengths and heights

are shown in the dimensional drawings (Fig. 5).

Table 1: *Technical data · All pressures (gauge)*

Type 2432 N Valve	
Nominal size	DN 15
Port	ISO 228/1 - G ¾ B
Type of connection	Threaded or welding ends
K _{V5} coefficient	2.5
Pressure rating	PN 16
Max. permissible differential pressure	Δp 6 bar
Max. permissible temperature	120 °C
Type 2430 Control Thermostat	
Set point range	Continuously adjustable 0 to 35 °C, 25 to 70 °C and 40 to 100 °C
Capillary tube	2 m · 5 m
Sensor connection	G ½ screw gland
Permissible ambient temperature range	-20 to +80 °C

Table 2: Materials · Material numbers according to DIN EN

Valve body (Type 2432)		CW602N
Plug	1.4301 and CW617N with EPDM seal	
Plug stem	1.4305	
Seat	CW602N	
Valve spring	1.4310 K	
Type 2430 Control Thermostat		
Sensor, capillary tube	Copper	
Set point adjuster	PTFE, glass fiber reinforced	
Accessories		
Welding end	S235JR (St 37-2)	
Threaded ends	Brass	
Thermowell	Copper or stainless steel 1.4571	

Table 3: Dimensions in mm · Weights in kg

Valve body (Type 2432)		
Pipe diameter	Ød	21.3
AF		30
Face-to-face dimensions	L	65
Face-to-face dimensions with welding ends	L1	210
Face-to-face dimensions with threaded ends	L2	129
Male thread	A	G ½
Height	H	150
Height	H1	30
Weight	kg (approx.)	0.3
Type 2430 Control Thermostat		
Height	H2	130
Diameter of control thermostat head	ØD	68
Immersion length of thermowell	L5	185
Sensor diameter	ØF	9.5
Thermowell diameter	ØT	12
Weight of control thermostat	kg (approx.)	0.9
Weight of thermowell	kg (approx.)	0.1

Dimensions

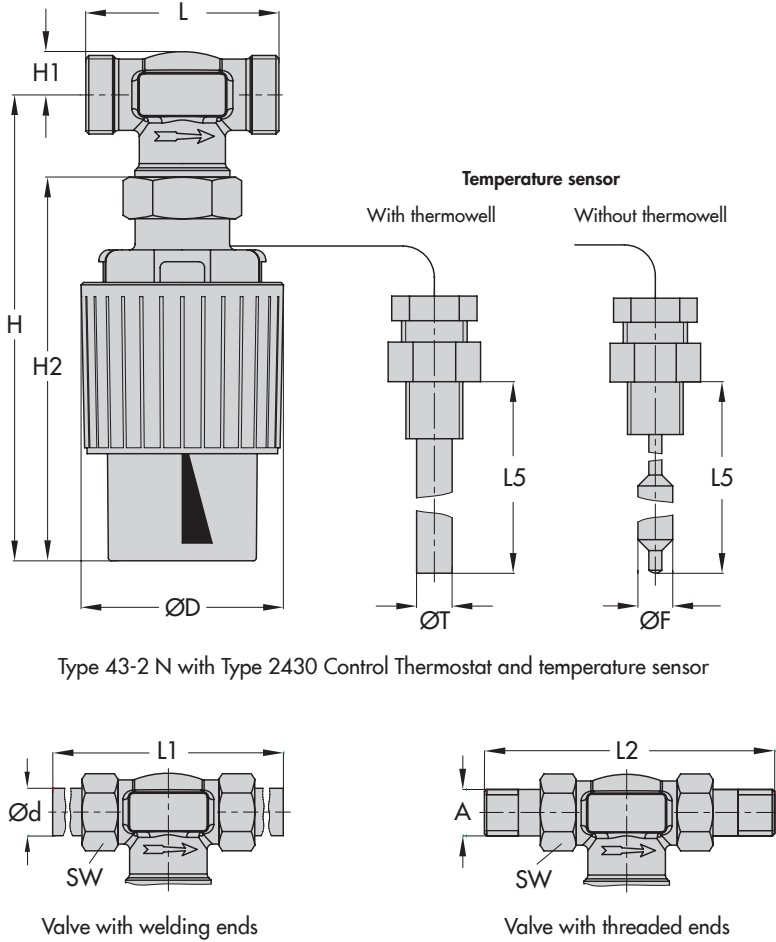

Type 43-2 N with Type 2430 Control Thermostat and temperature sensor

Fig. 5: Dimensions

4 Measures for preparation

After receiving the shipment, proceed as follows:

1. Check the scope of delivery. Compare the shipment received with the delivery note.
2. Check the shipment for transportation damage. Report any damage to SAMSON and the forwarding agent (refer to delivery note).

4.1 Unpacking

i Note

Do not remove the packaging until immediately before mounting it onto the valve.

Proceed as follows to lift and install the device:

1. Remove the packaging from the device.
2. Dispose of the packaging in accordance with the valid regulations.

4.2 Transporting and lifting

Due to the low service weight, lifting equipment is not required to transport and lift the temperature regulator.

Transport instructions

- Protect the device against external influences (e.g. impact).
- Do not damage the corrosion protection (paint, surface coatings). Repair any damage immediately.
- Protect the device against moisture and dirt.
- Observe the permissible ambient temperatures (see Chapter 3.2).

4.3 Storage

! NOTICE

Risk of temperature regulator damage due to improper storage.

- *Observe the storage instructions.*
 - *Avoid longer storage periods.*
 - *Contact SAMSON in case of different storage conditions or longer storage times.*
-

i Note

SAMSON recommends to regularly check the device and the prevailing storage conditions during long storage periods.

Mounting and start-up

Storage instructions

- Protect the temperature regulator against external influences (e.g. impact).
- Protect the device against moisture and dirt. Store it at a relative humidity of less than 75 %. In damp spaces, prevent condensation. If necessary, use a drying agent or heating.
- Make sure that the ambient air is free of acids or other corrosive media.
- Observe the permissible ambient temperatures (see Chapter 3.2).
- Do not place any objects on the device.



Our after-sales service can provide more detailed storage instructions on request.

4.4 Preparation for installation

Proceed as follows:

- ➔ Check the connection to install the temperature regulator into the pipeline to make sure that it is clean.
- ➔ Check the temperature regulator (valve and thermostat) for damage.
- ➔ Check to make sure that the type designation, pressure rating and temperature range of the temperature regulator match the plant conditions (nominal size and pressure rating of the pipeline, medium temperature etc.).
- ➔ Check any mounted thermometers to make sure they function.

5 Mounting and start-up

ⓘ NOTICE

Risk of overheating due to excessive ambient temperatures or insufficient heat dissipation when components are insulated.

- *Do not include the temperature regulator in the insulation of the pipeline.*

5.1 Mounting the control thermostat onto the valve

The Type 43-2 N Temperature Regulator consists of a Type 2432 Valve and a Type 2430 Control Thermostat. The Type 2430 Control Thermostat can be attached to the valve body either before or after the valve is installed in the pipeline.

- ➔ Attach the control thermostat (6) to the valve body (1) by tightening the coupling nut (15) with 20 Nm tightening torque.

5.2 Additional fittings

Strainer

A strainer installed upstream in the flow pipe holds back any dirt or other foreign particles carried along by the medium. For example, the SAMSON Type 1 NI Strainer is suitable (▶ T 1010).

The following points must be observed when installing the strainer:

- Do not use the strainer to permanently filter the process medium.
- Install the strainer upstream of the regulator.
- Allow sufficient space to remove the filter.
- Observe the flow direction through the strainer.
- In horizontal pipelines with gases or liquids, the filter element faces downward. The filter element faces sideways in applications with steam.

- Install strainers in vertical pipelines with the medium flowing upward with the drain plug facing upward.

Tip

Remember to leave enough space to remove the filter element for cleaning.

Shut-off valve

Install a hand-operated shut-off valve both upstream of the strainer and downstream of the regulator. This allows the plant to be shut down for cleaning and maintenance, and when the plant is not used for longer periods of time.

Thermometer

Install a thermometer downstream of the temperature sensor to monitor the temperatures prevailing in the plant (see Fig. 6).

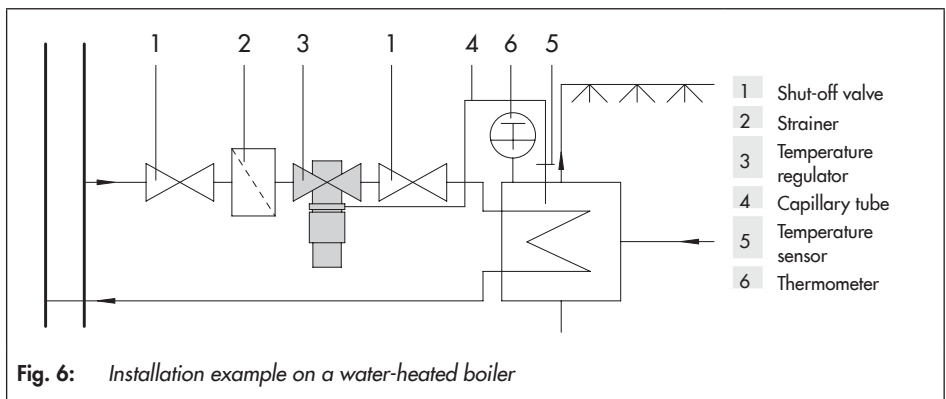

5.3 Installing the valve into the pipeline

5.3.1 Installation conditions

- Choose a place of installation that allows you to freely access the regulator even after the entire plant has been completed.
- Make sure the direction of flow matches the direction indicated by the arrow on the body.
- Install the regulator free of stress and with the least amount of vibrations as possible.
- Observe the permissible ambient temperature of max. 80 °C.

5.3.2 Installing the temperature sensor

! NOTICE

Risk of irreparable damage to the control thermostat caused by the thermostat components being taken apart.

Do not separate the control thermostat from the capillary tube or temperature sensor.

Mounting orientation

The mounting position of the temperature sensor depends on how the sensor functions.

The sensor operating according to the adsorption principle can be mounted in any desired position.

The mounting position of the sensor operating according to the vapor pressure principle depends on the installation situation

(▶ EB 2430-3).

! NOTICE

Risk of overheating or temperature fluctuations in the temperature control loop due to the sensor (or thermowell) being installed in the wrong location.

– *Select the site of installation where overheating or considerable idling times cannot occur.*

Installation without thermowell

The screw gland seals off the sensor.

- Weld a welding socket with G ½ female thread at the place of installation.
- Make sure that almost all of the process medium being monitored flows around the sensor (of Type 2430).
- Seal the screw gland into welded socket.

Installation with thermowell

The thermowell seals off the sensor.

- Weld a welding socket with G ½ female thread at the place of installation.
- Make sure that all of the process medium being monitored flows around the thermowell.
- Seal the thermowell into the welding socket.

For better heat transmission, we recommend filling the free space between sensor and thermowell with oil or, when installed hori-

zontally, with grease or any other heat transfer medium. This prevents heat transfer delays. Observe the thermal expansion of the filling medium. Allow some space for expansion and do not fill the entire free space or slightly loosen sensor nut for pressure compensation.

Capillary tube

- Carefully run the capillary tube (10) without bending or twisting it. Make sure that the capillary tube is not damaged.
- Observe the permissible ambient temperature of max. 80 °C over the entire length of the capillary tube.

⚠ NOTICE

Risk of capillary tube damage due to incorrect handling.

- Do not shorten the capillary tube.
- Roll up excess tube to form a ring. The smallest bending radius is 50 mm.

⚠ NOTICE

Galvanic corrosion due to incorrectly selected materials of the mounting parts.

On installing the thermowell in the pipeline, only use similar materials (e.g. stainless steel with stainless steel or copper together with other copper materials).

5.4 Start-up

Fill the plant very slowly with the process medium on start-up.

⚠ WARNING

Risk of burn injuries due to hot or cold components and pipelines.

Depending on the process medium, valve components and pipelines may get very hot or cold and cause burn injuries.

- Allow components and pipelines to cool down or warm up to the ambient temperature.
- Wear protective clothing and safety gloves.

⚠ NOTICE

Malfunction and damage due to adverse weather conditions (temperature, humidity).

Do not install the temperature regulator outdoors or in rooms prone to frost. If such a location cannot be avoided, protect the temperature regulator against freezing up if the process medium flowing through the valve can freeze up. Either heat the regulator or remove it from the plant and completely drain the residual medium.

After the control thermostat has been attached to the valve and the temperature sensor has been installed, the temperature regulator can be started up.

- Fill the plant very slowly with the process medium on start-up.
- Open the shut-off valves slowly preferably starting from the upstream pressure side.
- Avoid pressure surges.

6 Operation

See Fig. 4.

6.1 Adjusting the temperature

If the temperature regulator is to be adjusted, turn the black plastic ring according to the scale (see Table 4). To do this, proceed as follows:

1. If a sealing wire (14) exists, remove it.
2. Adjust the new temperature (see Table 4) at the set point adjuster (8).

Turn clockwise (↻) to reduce the temperature

Turn counterclockwise (↺) to increase the temperature

3. Lead-seal the temperature regulator (14), if applicable.

The setting of the temperature at the set point adjuster is continuously adjustable.

Table 4: Set point adjustment · Adjustment diagram

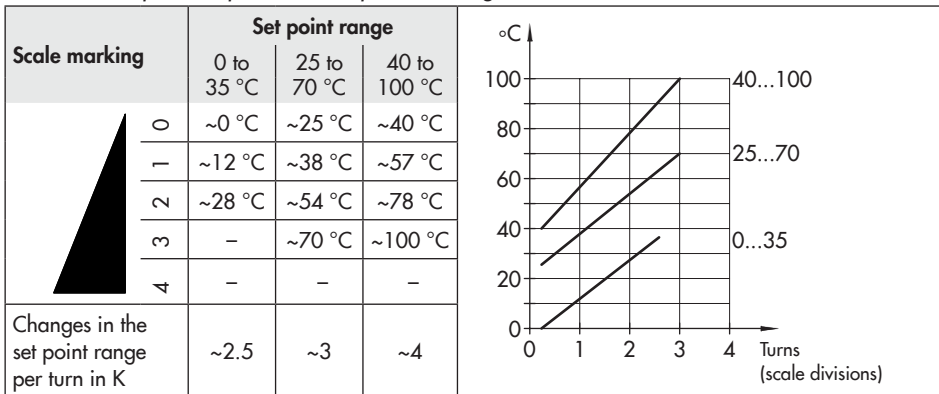

6.2 Servicing

The temperature regulator does not require much maintenance. Nevertheless, it is subject to natural wear, particularly at the soldered joints.

⚠ WARNING

Risk of burn injuries due to hot or cold components and pipeline.

Valve components and the pipeline may become very hot or cold. Risk of burn injuries.

- Allow components and pipelines to cool down or warm up to the ambient temperature.
- Wear protective clothing and safety gloves.

ⓘ NOTICE

Risk of damage to the valve or control thermostat due to over- or under-torquing.

The connection between valve and control thermostat must be tightened with a certain tightening torque. Excessive tightening torques lead to parts wearing out more quickly. Parts that are too loose may cause leakage.

Observe the specified tightening torques.

ⓘ Note

The device was checked by SAMSON before it left the factory.

- The product warranty becomes void if service or repair work not described in these instructions is performed without prior agreement by SAMSON's After-sales Service.
- Only use original spare parts by SAMSON, which comply with the original specifications.

6.3 Preparation for return shipment

Defective devices can be returned to SAMSON for repair. Proceed as follows to return devices to SAMSON:

1. Put the device out of operation (see Chapter 8.1).
2. Decontaminate the valve. Remove any residual process medium.
3. Fill in the Declaration on Contamination. The declaration form can be downloaded from our website at
 ► www.samsongroup.com > Service > After-sales Service > Returning goods.
4. Continue as described on our website at
 ► www.samsongroup.com > Service > After-sales Service > Returning goods.

7 Malfunctions

The malfunctions listed in Table 5 are caused by mechanical faults and incorrect regulator sizing. In the simplest case, the functioning can be restored following the recommended action. Special tools may be required for repair work.

Depending on the operating conditions, check the valve at certain intervals to prevent a possible failure before it can occur. Plant operators are responsible for drawing up an inspection and test plan.

Note

Contact SAMSON's After-sales Service for malfunctions not listed in the table.

Tip

SAMSON's After-sales Service can support you in drawing up an inspection and test plan for your plant.

8 Decommissioning and removal

DANGER

Risk of bursting in pressure equipment.

Valves and pipelines are pressure equipment. Improper opening can lead to bursting of the valve.

- Before starting any work on the valve, depressurize all plant sections affected as well as the valve.
 - Drain the process medium from the plant sections affected as well as from the valve.
 - Wear personal protective equipment.
-

WARNING

Risk of burn injuries due to hot or cold components and pipeline.

Valve components and the pipeline may become very hot or cold. Risk of burn injuries.

- Allow components and pipelines to cool down or warm up to the ambient temperature.
 - Wear protective clothing and safety gloves.
-

Table 5: Troubleshooting

Malfunction	Possible reasons	Recommended action
Temperature exceeds the adjusted temperature set point.	Temperature sensor installed in the wrong location.	→ Install the temperature sensor into the pipeline in such a way that the heat flow is correctly measured.
	Foreign particles blocking the valve plug	→ Remove foreign particles. → Replace damaged parts.
	Valve trim is worn out.	→ Replace damaged parts.
	Control thermostat defective	→ Replace the control thermostat.
Temperature drops below the set point adjusted at the control thermostat.	Valve installed against the flow.	→ Install the valve so that the direction of flow matches the direction indicated by the arrow on the body.
	Foreign particles blocking the valve plug	→ Remove foreign particles. → Replace damaged parts.
	Temperature sensor installed in the wrong location.	→ Install the temperature sensor into the pipeline in such a way that the heat flow is correctly measured.
	Valve or K_{VS}/C_V coefficient too small	→ Check the sizing. → Change K_{VS}/C_V coefficient, if necessary or install a different sized regulator.
	Flow temperature too low	→ Check the inlet temperature. → Contact the energy supplier, if necessary.
	Strainer blocked	→ Clean the strainer.
Jerky control response.	Increased friction, e.g. due to foreign particles between seat and plug.	→ Remove foreign particles. → Replace damaged parts.
	Temperature fluctuates.	Valve too large
Temperature sensor installed in the wrong location.		→ Install the temperature sensor into the pipeline in such a way that the heat flow is correctly measured (avoid dead times).
Leak at the joint between the valve and control thermostat.	Seal is defective	→ Replace damaged parts. → Contact SAMSON's After-sales Service.

8.1 Decommissioning

To decommission the temperature regulator before removing it, proceed as follows:

Steps 1 to 6 only apply when the thermowell is to be removed as well.

1. Close the shut-off valve on the upstream side of the valve.
2. Close the shut-off valve on the downstream side of the valve.
3. Completely drain the pipelines and valve.
4. Depressurize the plant.
5. If necessary, allow the pipeline and device to cool down or warm up to the ambient temperature.
6. Remove the thermowell from the pipeline and, if necessary, seal the opening.
7. Pull the sensor out of the thermowell.
8. Remove the control thermostat from the valve.

8.2 Disposal



SAMSON is a producer registered at the following European institution
▶ <https://www.ewrn.org/national-registers/national-registers>.
WEEE reg. no.:
DE 62194439/FR 025665

- Observe local, national and international refuse regulations.
- Do not dispose of components, lubricants and hazardous substances together with your other household waste.

i Note

SAMSON can provide you with a recycling passport according to PAS 1049 on request. Simply e-mail us at aftersaleservice@samsongroup.com giving details of your company address.

💡 Tip

On request, SAMSON can appoint a service provider to dismantle and recycle the product as part of a distributor take-back scheme.

9 Appendix

9.1 After-sales service and spare parts

After-sales service

Contact SAMSON's After-sales Service for support concerning service or repair work or when malfunctions or defects arise.

E-mail

You can reach our after-sales service at aftersalesservice@samson.de.

Addresses of SAMSON AG and its subsidiaries

The addresses of SAMSON, its subsidiaries, representatives and service facilities worldwide can be found on our website (▶ www.samsongroup.com) or in all SAMSON product catalogs.

To assist diagnosis and in case of an unclear mounting situation, specify the following details (so far as possible). See Chapter 2:

- Device type
- Model number and configuration ID
- Temperature and process medium
- Is a strainer installed?
- Installation drawing showing the exact location of the regulator and all the additionally installed components (shut-off valves, pressure gauge etc.)

Spare parts

No spare parts are available for the temperature regulator.

9.2 Tightening torques

Component	Nominal size	Tightening torque in Nm
Coupling nut (15)	All	20

10 Certificates

The EU declarations of conformity are included on the next pages.

SMART IN FLOW CONTROL.



**EU-KONFORMITÄTSERKLÄRUNG
EU DECLARATION OF CONFORMITY**

Modul H/Module H, Nr./No. / N° CE-0062-PED-H-SAM 001-16-DEU-rev-A

SAMSON erklärt in alleiniger Verantwortung für folgende Produkte:/For the following products, SAMSON hereby declares under its sole responsibility:

Ventile für Temperaturregler/Valves for temperature regulators

Typ/Type 2431, 2432, 2435, 2436, 2437 (Erz.-Nr./Model No. 2710)

die Konformität mit nachfolgender Anforderung/the conformity with the following requirement.

Richtlinie des Europäischen Parlaments und des Rates zur Harmonisierung der Rechtsvorschriften der Mitgliedstaaten über die Bereitstellung von Druckgeräten auf dem Markt. 2014/68/EU vom 15.05.2014

Directive of the European Parliament and of the Council on the harmonization of the laws of the Member States relating of the making available on the market of pressure equipment. 2014/68/EU of 15 May 2014

Angewandtes Konformitätsbewertungsverfahren für Fluide nach Art. 4(1)(c.i) erster Gedankenstrich. Modul siehe Tabelle durch certified by Bureau Veritas S. A. (0062)
Conformity assessment procedure applied for fluids according to Article 4(1)(c.i), first indent. See table for module

DN NPS	15 ½	20 ¾	25 1	32 1¼	40 1½	50 2	65 -	80 3	100 4	125 -	150 6	200 8	250 10	300 12	400 16
PN 16 (9) / PN 25	ohne (1)		A (2)(4)			H									
PN 40	ohne (1)		H												
Class 150	ohne (1)		A (2)(4)			H									
Class 300	ohne (1)		H												

(1) Das auf dem Stelgerät aufbrachte CE-Zeichen hat keine Gültigkeit im Sinne der Druckgeräterichtlinie.
The CE marking affixed to the control device does not refer to the Pressure Equipment Directive.

(2) Das auf dem Stelgerät aufbrachte CE-Zeichen gilt ohne Bezeichnung der Notifizierten Stelle (Kennr. 0062).
The CE marking affixed to the control device is valid, but does not refer to the notified body (ID No. is invalid).

(3) DN 15 auch in PN 16 lieferbar.
DN 15 as well in PN deliverable.

(4) Die Identifikationsnummer 0062 von Bureau Veritas S.A. gilt nicht für Modul A.
The identification number 0062 of Bureau Veritas S.A. is not valid for Modul A.

Geräte, denen laut Tabelle das Konformitätsbewertungsverfahren Modul H zugrunde liegt, beziehen sich auf die „Zulassungsbescheinigung eines Qualitätssicherungsystems“ ausgestellt durch die benannte Stelle.
Devices whose conformity has been assessed based on Module H refer to the certificate of approval for the quality management system issued by the notified body.

Dem Entwurf zu Grunde gelegt sind Verfahren aus:/The design is based on the procedures specified in the following standards:
DIN EN 12516-2, DIN EN 12516-3 bzw./or ASME B 16.24, ASME B 16.34

Das Qualitätssicherungssystem des Herstellers wird von folgender benannter Stelle überwacht:
The manufacturer's quality management system is monitored by the following notified body:

**Bureau Veritas S.A. Nr./No. 0062, Newtime, 52 Boulevard du Parc, Ile de la Jatte, 92200 Neuilly sur Seine, France
Hersteller:/Manufacturer: SAMSON AG, Weismüllerstraße 3, 60314 Frankfurt am Main, Germany**

Frankfurt am Main, 08. Februar 2017/08 February 2017

Klaus Hörtschken
Klaus Hörtschken
Zentralabteilungsleiter/Head of Central Department
Entwicklung Ventile und Antriebe/R&D, Valves and Actuators

Dr. Michael Heß
Dr. Michael Heß
Zentralabteilungsleiter/Head of Central Department
Product Management & Technical Sales

EU-Konformitätserklärung_BaH_09_Modul-A_Modul-H_DE-EN_Rev03_2017-02-08.docx

SAMSON AKTIENGESELLSCHAFT
Weismüllerstraße 3 60314 Frankfurt am Main

Telefon: 069 4009-0 · Telefax: 069 4009-1507 Revision 03
E-Mail: samson@samson.de

SMART IN FLOW CONTROL.



EU-KONFORMITÄTSERKLÄRUNG EU DECLARATION OF CONFORMITY

Modul H/Module H, Nr./No. / N° CE-0062-PED-H-SAM 001-16-DEU-rev-A

SAMSON erklärt in alleiniger Verantwortung für folgende Produkte:/For the following products, SAMSON hereby declares under its sole responsibility:

Ventile für Temperaturregler/Valves for temperature regulators

Typ/Type 2111, 2121, 2431, 2432, 2435, 2436, 2437 (Erz.-Nr./Model No. 2710), 2433, 2118 (2713), 2119 (2803), 2111, 2121 (2811), 2114 (2814)

die Konformität mit nachfolgender Anforderung/the conformity with the following requirement.

Richtlinie des Europäischen Parlaments und des Rates zur Harmonisierung der Rechtsvorschriften der Mitgliedstaaten über die Bereitstellung von Druckgeräten auf dem Markt. 2014/68/EU vom 15.05.2014

Directive of the European Parliament and of the Council on the harmonization of the laws of the Member States relating to the making available on the market of pressure equipment. 2014/68/EU of 15 May 2014

Angewandtes Konformitätsbewertungsverfahren für Fluide nach Art. 4(1)(c.ii) und (c.i) zweiter Gedankenstrich.

Modul siehe Tabelle

durch certified by Bureau Veritas S. A. (0062)

Conformity assessment procedure applied for fluids according to Article 4(1)(c.ii) and (c.i), second indent

See table for module

Druck Pressure rating	DN NPS	15 ½	20 ¾	25 1	32 1¼	40 1½	50 2	65	80 3	100 4	125	150 6	200 8	250 10	
PN 16		ohne/without ⁽¹⁾						A ⁽²⁾⁽³⁾			H				
PN 25		ohne/without ⁽¹⁾				A ⁽²⁾⁽³⁾		A ⁽²⁾⁽³⁾			H				
PN 40		ohne/without ⁽¹⁾		A ⁽²⁾⁽³⁾		A ⁽²⁾⁽³⁾		H			H				
Class 150		ohne/without ⁽¹⁾		A ⁽²⁾⁽³⁾		A ⁽²⁾⁽³⁾			H			H			
Class 300		ohne/without ⁽¹⁾		A ⁽²⁾⁽³⁾		A ⁽²⁾⁽³⁾			H			H			

(1) Das auf dem Stellgerät aufgebrachte CE-Zeichen hat keine Gültigkeit im Sinne der Druckgeräterichtlinie.
The CE marking affixed to the control valve is not valid in the sense of the Pressure Equipment Directive.

(2) Das auf dem Stellgerät aufgebrachte CE-Zeichen gilt ohne Bezeichnung der benannten Stelle (Kenn-Nr. 0062).
The CE marking affixed to the control valve is valid without specifying the notified body (ID number 0062).

(3) Die Identifikationsnummer 0062 von Bureau Veritas S.A. gilt nicht für Modul A.
The identification number 0062 of Bureau Veritas S.A. is not valid for Modul A.

Geräte, denen laut Tabelle das Konformitätsbewertungsverfahren Modul H zugrunde liegt, beziehen sich auf die „Zulassungsbescheinigung eines Qualitätssicherungssystems“ ausgestellt durch die Notifizierte Stelle.

Devices whose conformity has been assessed based on Module H refer to the certificate of approval for the quality management system issued by the notified body.

Dem Entwurf zu Grunde gelegt sind Verfahren aus/The design is based on the procedures specified in the following standards:
DIN EN 12516-2, DIN EN 12516-3 bzw./or ASME B16.1, ASME B16.24, ASME B16.34, ASME B16.42

Das Qualitätssicherungssystem des Herstellers wird von folgender benannter Stelle überwacht

The manufacturer's quality management system is monitored by the following notified body:

Bureau Veritas S.A. Nr./No. 0062, Newtime, 52 Boulevard du Parc, Ile de la Jatte, 92200 Neuilly sur Seine, France
Hersteller/Manufacturer: SAMSON AG, Weismüllerstraße 3, 60314 Frankfurt am Main, Germany

Frankfurt am Main, 08. Februar 2017/08 February 2017

Klaus Horschken

Klaus Horschken
Zentralabteilungsleiter/Head of Central Department
Entwicklung Ventile und Antriebe/R&D, Valves and Actuators

Dr. Michael Heß

Dr. Michael Heß
Zentralabteilungsleiter/Head of Central Department
Product Management & Technical Sales

EU-Konformitätserklärung_Büro_05_Modul-A_Modul-H_DE-EN_Rev03_2017-02-08.docx

SAMSON AKTIENGESELLSCHAFT
Weismüllerstraße 3 60314 Frankfurt am Main

Telefon: 069 4009-0 · Telefax: 069 4009-1507
E-Mail: samson@samson.de

Revision 03

EB 2186 EN



SAMSON AKTIENGESELLSCHAFT

Weismüllerstraße 3 · 60314 Frankfurt am Main, Germany

Phone: +49 69 4009-0 · Fax: +49 69 4009-1507

samson@samsongroup.com · www.samsongroup.com