

MOUNTING AND OPERATING INSTRUCTIONS



EB 2520 EN

Translation of original instructions



Type 2405 Pressure Reducing Valve Self-operated Pressure Regulators

Edition July 2024

UK
CA CE EAC

Note on these mounting and operating instructions

These mounting and operating instructions assist you in mounting and operating the device safely. The instructions are binding for handling SAMSON devices. The images shown in these instructions are for illustration purposes only. The actual product may vary.

- For the safe and proper use of these instructions, read them carefully and keep them for later reference.
- If you have any questions about these instructions, contact SAMSON's After-sales Service Department (aftersaleservice@samsongroup.com).



Documents relating to the device, such as the mounting and operating instructions, are available on our website at www.samsongroup.com > **Downloads > Documentation.**

Definition of signal words

DANGER

Hazardous situations which, if not avoided, will result in death or serious injury

WARNING

Hazardous situations which, if not avoided, could result in death or serious injury

NOTICE

Property damage message or malfunction

Note

Additional information

Tip

Recommended action

1	Safety instructions and measures	4
1.1	Notes on possible severe personal injury	7
1.2	Notes on possible personal injury	8
1.3	Notes on possible property damage	8
2	Markings on the device	10
2.1	Regulator nameplate	10
2.2	Location of the nameplate	11
2.3	Material identification number	11
3	Design and principle of operation	12
3.1	Technical data	16
4	Measures for preparation	21
4.1	Unpacking	21
4.2	Transporting and lifting	21
5	Mounting and start-up	22
5.1	Installing the valve into the pipeline	22
4.3	Storage	22
4.4	Preparation for installation	22
5.1.1	Installation conditions	23
5.1.2	Mounting orientation	24
5.1.3	Additional fittings	24
5.2	Quick check	26
5.3	Putting the regulator into operation	26
5.4	Adjusting the set point	26
6	Servicing	27
6.1	Preparation for return shipment	28
6.2	Ordering spare parts and operating supplies	28
7	Malfunctions	29
7.1	Troubleshooting	29
8	Decommissioning and removal	30
8.1	Decommissioning	30
8.2	Removing the valve from the pipeline	30
9	Disposal	31
10	Appendix	31
10.1	After-sales service	31
11	Certificates	32
11.1	Information on the UK sales region	32

1 Safety instructions and measures

Intended use

The Type 2405 Pressure Reducing Valve is used to control the pressure of flammable gases used as a source of energy, e.g. in boilers, driers, vaporizers, heat exchangers or industrial ovens. Alternatively, it can control the compressed air supply in process engineering applications.

The device is designed to operate under exactly defined conditions (e.g. operating pressure, process medium, temperature). Therefore, operators must ensure that the device is only used in operating conditions that meet the specifications used for sizing the device at the ordering stage. In case operators intend to use the device in applications or conditions other than those specified, contact SAMSON.

SAMSON does not assume any liability for damage resulting from the failure to use the device for its intended purpose or for damage caused by external forces or any other external factors.

→ Refer to the technical data and nameplate for limits and fields of application as well as possible uses.

Reasonably foreseeable misuse

The regulators are not suitable for the following applications:

- Use outside the limits defined during sizing and by the technical data
- Use outside the limits defined by the additional fittings mounted on the regulator

Furthermore, the following activities do not comply with the intended use:

- Use as safety valve
- Use of non-original spare parts
- Performing service and repair work not described

Qualifications of operating personnel

The device must be mounted, started up, serviced and repaired by fully trained and qualified personnel only; the accepted industry codes and practices must be observed. According to these mounting and operating instructions, trained personnel refers to individuals who are able to judge the work they are assigned to and recognize possible hazards due to their specialized training, their knowledge and experience as well as their knowledge of the applicable standards.

Personal protective equipment

SAMSON recommends checking the hazards posed by the process medium being used (e.g. ► GESTIS (CLP) hazardous substances database). Depending on the process medium and/or the activity, the protective equipment required includes:

- Protective clothing, safety gloves and eye protection in applications with hot, cold and/or corrosive media
 - Wear hearing protection when working near the valve. Follow the instructions given by the plant operator.
 - Hard hat
 - Safety harness, e.g. when working at height
 - Safety footwear, if applicable ESD (electrostatic discharge) footwear
- ➔ Check with the plant operator for details on further protective equipment.

Revisions and other modifications

Revisions, conversions or other modifications of the product are not authorized by SAMSON. They are performed at the user's own risk and may lead to safety hazards, for example. Furthermore, the product may no longer meet the requirements for its intended use.

Warning against residual hazards

To avoid personal injury or property damage, plant operators and operating personnel must prevent hazards that could be caused in the regulator by the process medium, the operating pressure or by moving parts by taking appropriate precautions. Plant operators and operating personnel must observe all hazard statements, warnings and caution notes in these mounting and operating instructions.

Hazards resulting from the special working conditions at the installation site of the regulator must be identified in a risk assessment and prevented through the corresponding safety instructions drawn up by the operator.

SAMSON also recommends checking the hazards posed by the process medium being used (e.g. ► GESTIS (CLP) hazardous substances database).

- ➔ Observe safety measures for handling the device as well as fire prevention and explosion protection measures.

These mounting and operating instructions deal with the standard version of the device. Components of the device that differ to those used for the standard version described in this document can be exchanged with other certain SAMSON components. The residual hazards of these components are described in the associated mounting and operating instructions (see 'Referenced documents' chapter).

Safety instructions and measures

Responsibilities of the operator

Operators are responsible for proper use and compliance with the safety regulations. Operators are obliged to provide these mounting and operating instructions as well as the referenced documents to the operating personnel and to instruct them in proper operation. Furthermore, operators must ensure that operating personnel or third parties are not exposed to any danger.

Operators are additionally responsible for ensuring that the limits for the product defined in the technical data are observed. This also applies to the start-up and shutdown procedures. Start-up and shutdown procedures fall within the scope of the operator's duties and, as such, are not part of these mounting and operating instructions. SAMSON is unable to make any statements about these procedures since the operative details (e.g. differential pressures and temperatures) vary in each individual case and are only known to the operator.

Responsibilities of operating personnel

Operating personnel must read and understand these mounting and operating instructions as well as the referenced documents and observe the specified hazard statements, warnings and caution notes. Furthermore, operating personnel must be familiar with the applicable health, safety and accident prevention regulations and comply with them.

Safety features

The Type 2405 Regulator does not have any special safety features. When relieved of pressure, the regulator is opened by the force of the set point springs.

Referenced standards, directives and regulations

The regulators comply with the requirements of the European Pressure Equipment Directive 2014/68/EU, Machinery Directive 2006/42/EC, Directive 2016 No. 1105 Pressure Equipment (Safety) Regulations 2016 and Directive 2008 No. 1597 Supply of Machinery (Safety) Regulations 2008. Regulators with a CE marking and/or UKCA marking have a declaration of conformity, which includes information about the applied conformity assessment procedure. This declaration of conformity is included in the Appendix of these instructions (see Chapter 11).

Non-electric valve versions whose bodies are not lined with an insulating material coating do not have their own potential ignition source according to the hazard assessment stipulated in Clause 5.2 of ISO 80079-36, even in the rare incident of an operating fault. Therefore, such valve versions do not fall within the scope of Directive 2014/34/EU.

→ For connection to the equipotential bonding system, observe the requirements specified in Clause 6.4 of EN 60079-14 (VDE 0165-1).

Referenced documents

The following documents apply in addition to these mounting and operating instructions:

- Mounting and operating instructions for
e.g. **Type 2 N or 2 NI Strainer** ▶ EB 1015
- Data sheets for
e.g. **Type 2 N or 2 NI Strainer** ▶ T 1015
- Mounting and operating instructions as well as data sheets for additional components (e.g. shut-off valves, pressure gauges etc.).

1.1 Notes on possible severe personal injury

DANGER

Risk of bursting in pressure equipment.

Valves and pipelines are pressure equipment. Improper opening can lead to valve components bursting.

- Observe the maximum permissible pressure for valve and plant.
- Before starting any work on the valve, depressurize all plant sections affected as well as the valve.
- To prevent uncontrolled excess pressure, make sure that suitable overpressure protection is installed on site in the plant section.
- Drain the process medium from the plant sections affected as well as from the valve.
- Wear personal protective equipment.

1.2 Notes on possible personal injury

WARNING

Risk of personal injury due to residual process medium in the valve.

While working on the valve, residual medium can flow out of the valve and, depending on its properties, cause personal injury, e.g. (chemical) burns.

- If possible, drain the process medium from the plant sections affected and from the valve.
- Wear protective clothing, safety gloves and eye protection.

Risk of burn injuries due to hot or cold components and pipelines.

Depending on the process medium, valve components and pipelines may get very hot or cold and cause burn injuries.

- Allow components and pipelines to cool down or warm up to the ambient temperature.
- Wear protective clothing and safety gloves.

Damage to health relating to the REACH regulation.

If a SAMSON device contains a substance listed as a substance of very high concern on the candidate list of the REACH regulation, this is indicated on the SAMSON delivery note.

- Information on the safe use of the part affected: go to [u https://www.samsongroup.com/en/about-samson/environment-social-governance/material-compliance/reach-regulation/](https://www.samsongroup.com/en/about-samson/environment-social-governance/material-compliance/reach-regulation/)

1.3 Notes on possible property damage

NOTICE

Risk of valve damage due to contamination (e.g. solid particles) in the pipeline.

The plant operator is responsible for cleaning the pipelines in the plant.

- Flush the pipelines before start-up.

Risk of regulator damage due to the use of unsuitable lubricants.

The lubricants to be used depend on the regulator material. Unsuitable lubricants may corrode and damage surfaces.

- Only use lubricants approved by SAMSON.
When in doubt, consult SAMSON.

! NOTICE

Risk of valve damage due to unsuitable medium properties.

The valve is designed for a process medium with defined properties.

→ Only use the process medium specified for sizing the equipment.

Risk of regulator damage due to incorrectly attached slings.

→ Do not attach load-bearing slings to the actuator housing.

Risk of leakage and valve damage due to over- or under-torquing.

Observe the specified torques when tightening valve components.

Excessive tightening torques lead to parts wearing out more quickly. Parts that are too loose may cause leakage.

→ Observe the specified tightening torques.

Risk of regulator damage due to the use of unsuitable tools.

Certain tools are required to work on the regulator.

→ Only use tools approved by SAMSON.
When in doubt, consult SAMSON.

Risk of excess pressure damaging plant sections due to construction-related seat leakage through the regulator.

→ Always install a safety device (e.g. safety excess pressure valve or safety relief valve) in the plant.

Risk of regulator damage due to the installation of solenoid valves.

If solenoid valves are installed downstream of the regulator when the regulator is used to control liquids, pressure peaks may occur when the solenoid valves close quickly. These pressure peaks can damage the regulator.

→ The installation of solenoid valves downstream of the regulator is not permitted when the regulator is used to control liquids.
When in doubt, consult SAMSON.

i Note

SAMSON's After-sales Service can support you concerning lubricant, tightening torques and tools approved by SAMSON.

2 Markings on the device

The nameplate shown was up to date at the time of publication of this document. The nameplate on the device may differ from the one shown.

2.1 Regulator nameplate

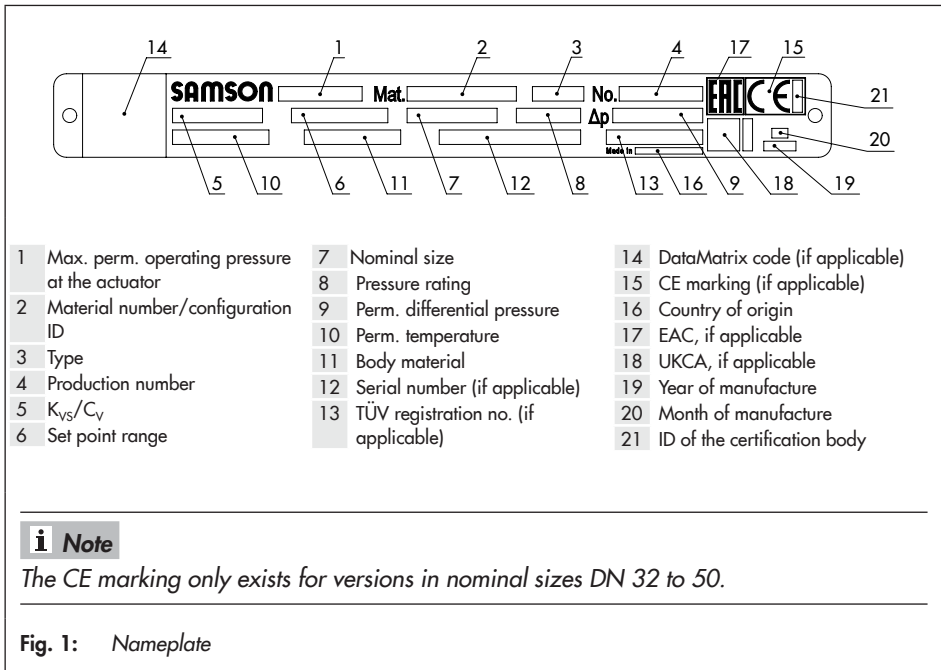

i Note

The CE marking only exists for versions in nominal sizes DN 32 to 50.

Fig. 1: Nameplate

2.2 Location of the nameplate

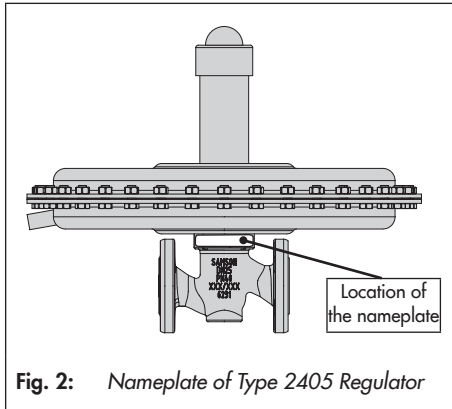

Fig. 2: Nameplate of Type 2405 Regulator

2.3 Material identification number

See the nameplate (11, body material). For more details on the nameplate, see Chapter 2.1.

3 Design and principle of operation

The medium flows through the regulator in the direction indicated by the arrow. The position of the plug (3) determines the cross-sectional area of flow between the plug and the seat (2).

– Pressure reducing valve with proportional control action (see Fig. 3)

In the pressureless state (control line not connected and no pressure applied) the valve is opened by the force of the set point springs (27). The spring force is adjustable at the set point adjuster (30).

The downstream pressure p_2 to be controlled is tapped downstream of the regulator and transmitted over an external control line to the control line connection (9) on the actuator housing (20) where it is converted into a positioning force by the diaphragm plate (18) with operating diaphragm (21). The diaphragm moves the plug over the plug stem (4) depending on the force of the set point springs.

When the force resulting from the downstream pressure p_2 rises above the spring force adjusted at the set point springs, the valve closes proportionally to the change in pressure.

In the version with pressure balancing, the forces produced by the upstream and downstream pressures acting on the plug are eliminated by the balancing diaphragm (8). The plug is fully balanced.

– Pressure reducing valve with two-step control mode (see Fig. 4)

The regulator (nominal sizes DN 32 to 50/ NPS 1½ and NPS 2, K_{VS} 16, 20 and 32/ C_V 20 and 37 with set point ranges from 0.005 to 0.060 bar) operates as a two-step controller.

A differential pressure of at least 1.6 bar is required for troublefree operation.

In the idle state, the valve is closed when the pressure in the bottom actuator chamber is equal or higher than the set point. The set point is adjusted by tensioning the set point spring (27) at the set point adjuster (30).

The upstream pressure p_1 is routed through a hole in the plug stem to the chamber of the plug balancing unit above the balancing diaphragm (8).

The valve is pressure-balanced in this way.

The required closing force of the plug is generated by the compression spring (542) in the chamber.

If the downstream pressure p_2 being controlled drops below the lower switching point of the adjusted set point, the force created by the diaphragm (21) is lower than the force of the set point spring (27). This causes the diaphragm plate (18), which is fastened to the actuator stem (540), to be pushed down moving towards the plug. This results in a force being exerted on the tappet, which is part of the assembly (535) of the internal bypass valve.

The pressure in the balancing chamber is relieved to the downstream side.

The balancing pressure drops until it reaches

the level of the downstream pressure p_2 . As a result, the upstream pressure exerted on the plug is able to fully open the valve opposing the force of the compression spring (542).

If the downstream pressure p_2 starts to rise again and reaches the upper switching point of the adjusted set point, the diaphragm plate (18) and actuator stem (540) with it are lifted. The internal bypass valve closes and the upstream pressure p_1 starts to build up again in the chamber of the plug balancing unit above the balancing diaphragm (8). The pressure-balanced state of the valve is restored and the compression spring (542) causes the plug to close.

The two-step control mode is determined by a switching accuracy of ≤ 1.5 mbar between the upper and lower switching point.

The regulator is additionally fitted with a shipping lock (222, 223), which must be removed before start-up. A warning is provided by a yellow label (224) on the regulator. The shipping lock prevents any shocks or impacts from being transferred to the control unit, which could damage it.

NOTICE

The regulator will be damaged if the shipping lock is not removed.

It is essential that the shipping lock is removed before testing or start-up.

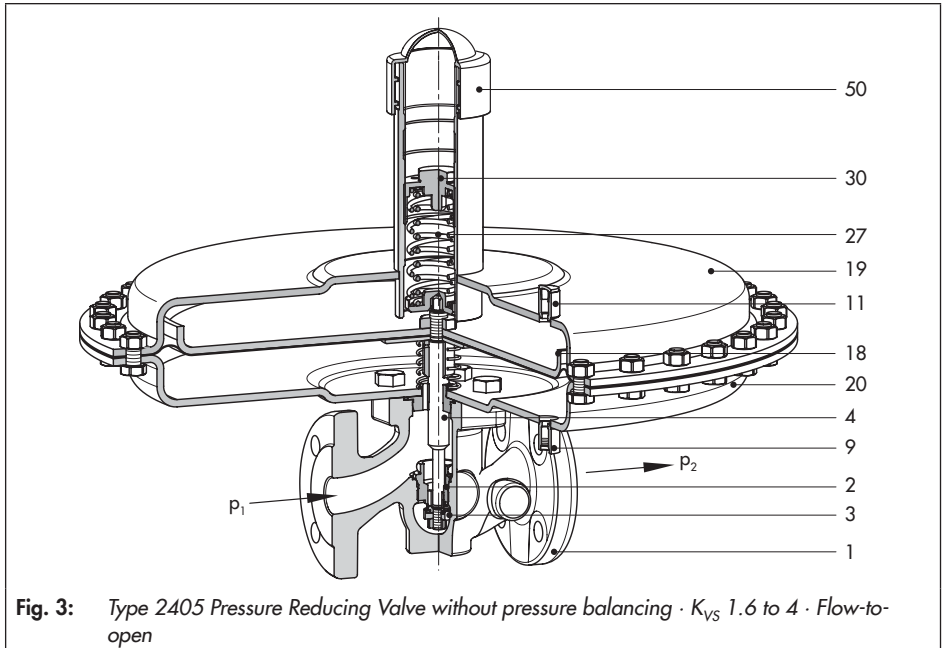

Fig. 3: Type 2405 Pressure Reducing Valve without pressure balancing · K_{VS} 1.6 to 4 · Flow-to-open

Design and principle of operation

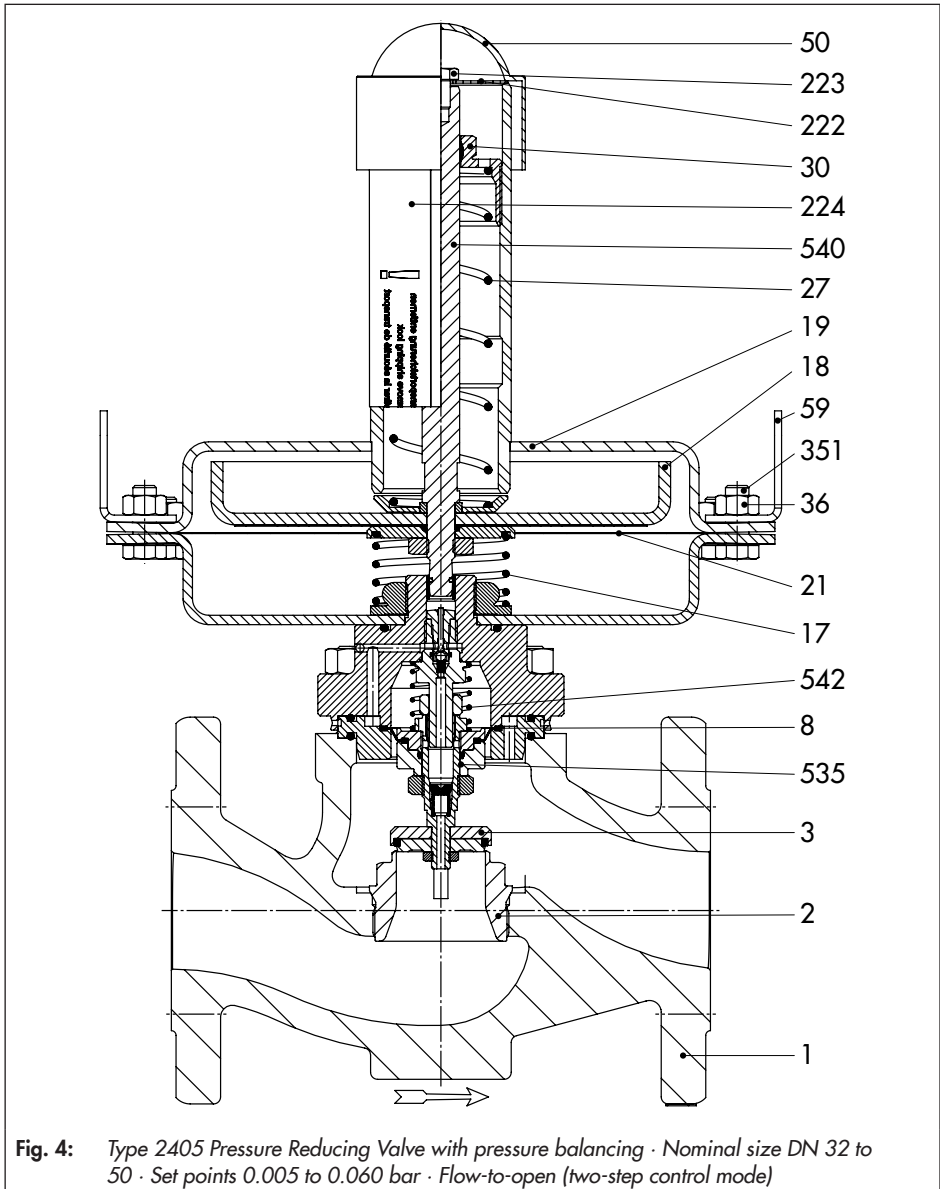
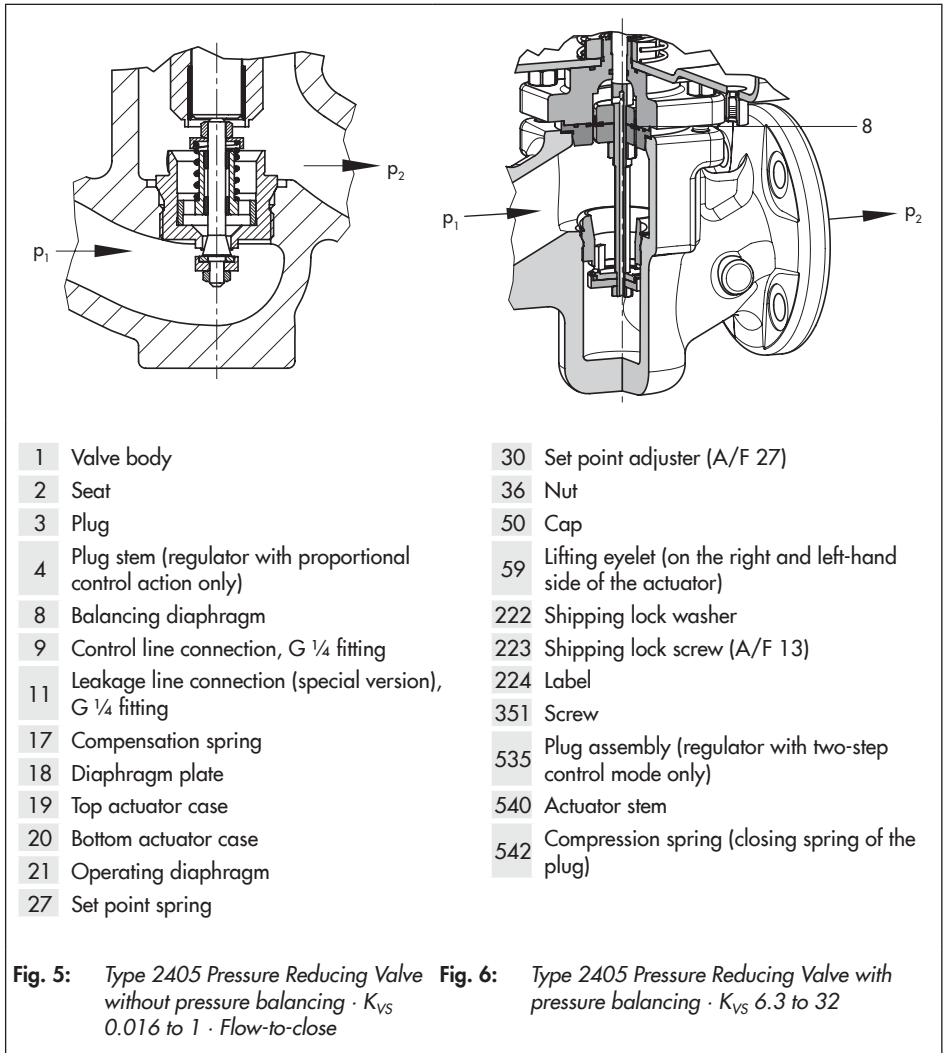

Fig. 4: Type 2405 Pressure Reducing Valve with pressure balancing · Nominal size DN 32 to 50 · Set points 0.005 to 0.060 bar · Flow-to-open (two-step control mode)



- 1 Valve body
- 2 Seat
- 3 Plug
- 4 Plug stem (regulator with proportional control action only)
- 8 Balancing diaphragm
- 9 Control line connection, G ¼ fitting
- 11 Leakage line connection (special version), G ¼ fitting
- 17 Compensation spring
- 18 Diaphragm plate
- 19 Top actuator case
- 20 Bottom actuator case
- 21 Operating diaphragm
- 27 Set point spring

- 30 Set point adjuster (A/F 27)
- 36 Nut
- 50 Cap
- 59 Lifting eyelet (on the right and left-hand side of the actuator)
- 222 Shipping lock washer
- 223 Shipping lock screw (A/F 13)
- 224 Label
- 351 Screw
- 535 Plug assembly (regulator with two-step control mode only)
- 540 Actuator stem
- 542 Compression spring (closing spring of the plug)

3.1 Technical data

The valve and actuator nameplates provide information on the valve and actuator versions (see Chapter 2.1).

Process medium and scope of application

The Type 2405 Pressure Reducing Valve is used to maintain the pressure downstream of the valve to an adjusted set point.

- For **gases**
- Temperature range **-20 to +60 °C**
- Set points **from 5 mbar to 10 bar**
- Nominal size **DN 15 to 50**
- Pressure ratings from **PN 16 to 40**

The regulator is open when relieved of pressure. The valve **closes** when the **downstream** pressure rises.

The regulator version with two-step control mode is closed when relieved of pressure.

The valve **closes** when the **downstream** pressure rises and opens when the downstream pressure falls below the adjusted set point by more than 1.6 bar.

Temperature range

Depending on how the regulator is configured, it can be used up to temperatures of 60 °C (Table 1).

Temperature range from 0 to 150 °C for unbalanced versions with FKM diaphragm and FKM soft seal

Leakage class

The soft-seated regulator has the leakage class IV according to IEC 60534-4.

Noise emissions

SAMSON is unable to make general statements about noise emissions. The noise emissions depend on the regulator version, plant facilities, process medium and operating conditions.

WARNING

Risk of hearing loss or deafness due to loud noise.

Wear hearing protection when working near the regulator.

Note

The Type 2405 Regulator is not a safety valve. If necessary, a suitable overpressure protection must be installed on site in the plant section.

Options

- With pressure balancing (see Fig. 6)
- Pressure tapping directly at the valve instead of over an external control line with 0.8 to 2.5 bar, 2 to 5 bar and 4.5 to 10 bar

Dimensions and weights

Table 3 and Table 4 provide an overview of the dimensions and weights. The lengths and heights in the dimensional drawings are shown on page 20.

Table 1: *Technical data · Pressure reducing valve with proportional control action*

Nominal size		DN 15	DN 20	DN 25	DN 32	DN 40	DN 50
Pressure rating (valve)		PN 16 · PN 25 · PN 40					
K _{VS} coefficients	Standard	4.0	6.3	8.0	16 ⁵⁾	20 ⁵⁾	32 ⁵⁾
	Reduced K _{VS}	0.016 · 0.04 · 0.1	0.016 · 0.04 · 0.1	0.016 · 0.04 · 0.1 · 0.25	1.6 · 2.5 · 4.0 · 6.3	1.6 · 2.5 · 4.0 · 6.3	1.6 · 2.5 · 4.0 · 6.3
		· 0.25 · 0.4 · 1.0 · 1.6 · 2.5	0.25 · 0.4 · 1.0 · 1.6 · 2.5 · 4.0	0.4 · 1.0 · 1.6 · 2.5 · 4.0 · 6.3	8.0	8.0 · 16	8.0 · 16 · 20
Max. perm. differential pressure		10 bar · 12 bar ¹⁾					
Max. permissible temperature range (medium temperature)		-20 to +60 °C (0 to +150 °C) ²⁾					
Leakage class acc. to IEC 60534-4		Soft-seated, minimum Class IV					
Conformity							
Set point ranges		5 to 15 mbar · 10 to 30 mbar · 25 to 60 mbar · 50 to 200 mbar · 0.1 to 0.6 bar · 0.2 to 1 bar · 0.8 to 2.5 bar · 2 to 5 bar · 4.5 to 10 bar					
Max. perm. pressure at operating diaphragm	1200 cm ²	5 to 15 mbar			5 to 15 mbar · 10 to 30 mbar		
		0.5 bar					
	640 cm ²	10 to 30 mbar · 25 to 60 mbar			25 to 60 mbar		
		1 bar					
	320 cm ²	50 to 200 mbar · 0.1 to 0.6 bar					
	160 cm ²	2 bar · 10 bar³⁾					
	80 cm ²	0.2 to 1 bar 3 bar · 16 bar³⁾					
40 cm ²	0.8 to 2.5 bar						
	5 bar · 16 bar³⁾						
	2 to 5 bar						
Pressure balancing	K _{VS} = 0.016 to 4	Without balancing diaphragm					
	K _{VS} = 6.3 to 32	With balancing diaphragm					
Pressure tapping		External ⁴⁾					
Control line connection		G ¼					

1) Version with set points from 0.1 to 10 bar

2) For unbalanced versions with FKM diaphragm and FKM soft seal

3) Version with force limiter

4) Special version with pressure tapping directly at the valve (see Chapter 3.1)

5) Version with two-step control mode only · The K_{VS} coefficients cannot be combined with the set points: 5 to 15 mbar · 10 to 30 mbar · 25 to 60 mbar

Design and principle of operation

Table 2: Technical data · Pressure reducing valve with two-step control mode

Nominal size	DN 32	DN 40	DN 50
Pressure rating (valve)	PN 16 · PN 25 · PN 40		
K _{VS} coefficients	16	20	32
Min. required differential pressure	1.6 bar		
Max. permissible differential pressure	10 bar		
Switching accuracy	≤1.5 mbar		
Max. permissible temperature range (medium temperature)	-20 to +60 °C		
Leakage class according to IEC 60534-4	Soft-seated, minimum Class IV		
Conformity			
Set point ranges	5 to 15 mbar · 10 to 30 mbar · 25 to 60 mbar		
Max. perm. pressure at operating diaphragm with a set point range	5 to 15 mbar	0.5 bar	
	10 to 30 mbar		
	25 to 60 mbar		
Pressure balancing	With balancing diaphragm		
Pressure tapping	External		
Control line connection	G ¼		

Table 3: Weights in kg ¹⁾

Nominal size	DN 15	DN 20	DN 25	DN 32	DN 40	DN 50
Set point range	5 to 15 mbar	28			40	
	10 to 30 mbar	18			40	
	25 to 60 mbar	14			30	
	50 to 200 mbar	14			26	
	0.1 to 0.6 bar	14			26	
	0.2 to 1 bar	10			22	
	0.8 to 2.5 bar	8			20	
	2 to 5 bar	8			20	
4.5 to 10 bar	9			21		

¹⁾ Body made of cast steel 1.0619: +10 %

Table 4: Dimensions in mm

Nominal size		DN 15	DN 20	DN 25	DN 32	DN 40	DN 50	
Length L		130	150	160	180	200	230	
Height H2	Forged steel	53	–	70	–	92	98	
	Other materials	44		72				
Set point range	5 to 15 mbar	Height H	Without balancing	325		370		
			With balancing	352		370 · 387 ¹⁾		
	Actuator		ØD = 485 mm, A = 1200 cm ²					
	10 to 30 mbar	Height H	Without balancing	318		366		
			With balancing	345		370 · 387 ¹⁾		
	Actuator		ØD = 380 mm, A = 640 cm ²		ØD = 485 mm, A = 1200 cm ²			
	25 to 60 mbar	Height H	Without balancing	318		366		
			With balancing	345		370 · 380 ¹⁾		
	Actuator		ØD = 380 mm, A = 640 cm ²					
	50 to 200 mbar	Height H	Without balancing	318		366		
			With balancing	345		370		
	Actuator		ØD = 285 mm, A = 320 cm ²					
	0.1 to 0.6 bar	Height H	Without balancing	318		366		
			With balancing	345		370		
	Actuator		ØD = 285 mm, A = 320 cm ²					
	0.2 to 1 bar	Height H	Without balancing	318		366		
			With balancing	345		370		
	Actuator		ØD = 225 mm, A = 160 cm ²					
	0.8 to 2.5 bar	Height H	Without balancing	330		365		
			With balancing	356		369		
Actuator		ØD = 170 mm, A = 80 cm ²						
2 to 5 bar	Height H	Without balancing	333		368 mm			
		With balancing	359		373 mm			
Actuator		ØD = 170 mm, A = 40 cm ²						
4.5 to 10 bar	Height H	Without balancing	437		485			
		With balancing	463		489			
Actuator		ØD = 170 mm, A = 40 cm ²						

¹⁾ For the regulator version with two-step control mode only

Dimensional drawings

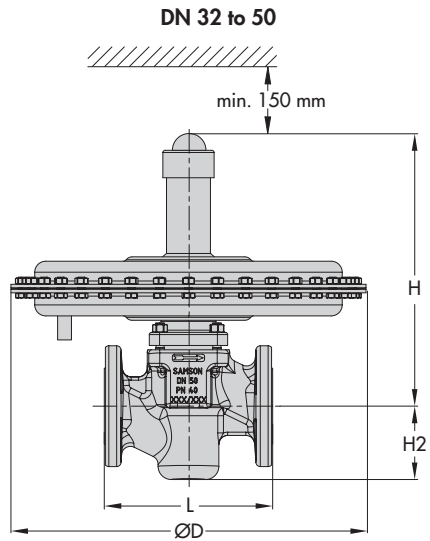
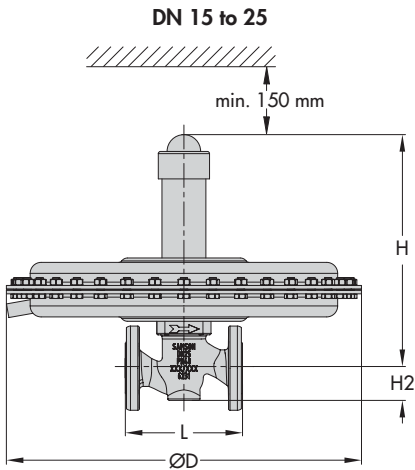

Control line connection G ¼, for A = 40, 80, 160 and 320 cm²

Control line connection G ¼, for A = 640 and 1200 cm²

The control line connection is turned by 90° in the drawing. The connection is normally located opposite the side with the arrow indicating the direction of flow.

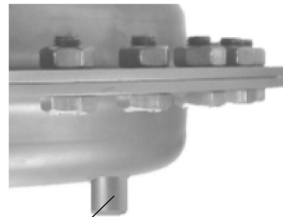
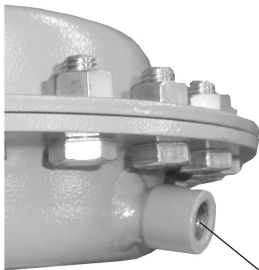

G ¼ fitting

Control line connection at the side of the actuator housing

Control line connection on the bottom of the actuator housing

Fig. 7: Dimensions of Type 2405

4 Measures for preparation

After receiving the shipment, proceed as follows:

1. Check the scope of delivery. Compare the shipment received with the delivery note.
2. Check the shipment for transportation damage. Report any damage to SAMSON and the forwarding agent (refer to delivery note).

4.1 Unpacking

Do not remove the packaging until immediately before installing the valve into the pipeline.

Proceed as follows to lift and install the device:

1. Remove the packaging from the device.
2. Dispose of the packaging in accordance with the valid regulations.

4.2 Transporting and lifting

Due to the low service weight, lifting equipment is not required to lift and transport the device (e.g. to install it into the pipeline).

! NOTICE

Risk of valve damage due to incorrectly attached lifting equipment.

Do not attach lifting equipment to mounting parts (e.g. control line).

Transport instructions

- Protect the device against external influences (e.g. impact).
- Do not damage the corrosion protection (paint, surface coatings). Repair any damage immediately.
- Protect the device against moisture and dirt.
- Observe the permissible ambient temperatures (see Chapter 3.1).

4.3 Storage

NOTICE

Risk of regulator damage due to improper storage.

- Observe the storage instructions.
- Avoid longer storage periods.

Contact SAMSON in case of different storage conditions or longer storage times.

Note

SAMSON recommends to regularly check the device and the prevailing storage conditions during long storage periods.

Storage instructions

- Protect the device against external influences (e.g. impact).
- Do not damage the corrosion protection (paint, surface coatings). Repair any damage immediately.
- Protect the device against moisture and dirt. Store it at a relative humidity of less than 75 %. In damp spaces, prevent condensation. If necessary, use a drying agent or heating.
- Make sure that the ambient air is free of acids or other corrosive media.
- Observe the permissible ambient temperatures (see Chapter 3.1).
- Do not place any objects on the device.

4.4 Preparation for installation

- Flush the pipelines.

Note

The plant operator is responsible for cleaning the pipelines in the plant.

- Ensure that there is no liquid, e.g. condensed water, inside the regulator. If necessary, blow out the connecting parts with clean compressed air.
- Check the valve to make sure that it is clean.
- Check the valve for damage.
- Check to make sure that the type designation, nominal size, material, pressure rating and temperature range of the valve match the plant conditions (nominal size and pressure rating of the pipeline, medium temperature etc.).

5 Mounting and start-up

5.1 Installing the valve into the pipeline

NOTICE

Damage due to pressure peaks.

If solenoid valves are installed downstream of the regulator when the regulator is used to control liquids, pressure peaks may occur when the solenoid valves close quickly. The installation of solenoid valves is not permitted when the regulator is used to control liquids.

5.1.1 Installation conditions

- Choose a place of installation that allows you to freely access the regulator even after the entire plant has been completed.
- The type and dimensions of the pipeline and tank connections must suit the regulator.
- Make sure the direction of flow matches the direction indicated by the arrow on the body.
- Install the regulator free of stress and with the least amount of vibrations as possible. If necessary, support the pipeline near the connecting flanges. Do not attach supports directly to the valve or actuator.
- Protect the regulator from icing up when controlling media that can freeze. Unless the regulator is installed in locations where no frost occurs, remove the regulator from the pipeline when the plant is shut down.
- Observe the permissible ambient temperatures (see Chapter 3.1).

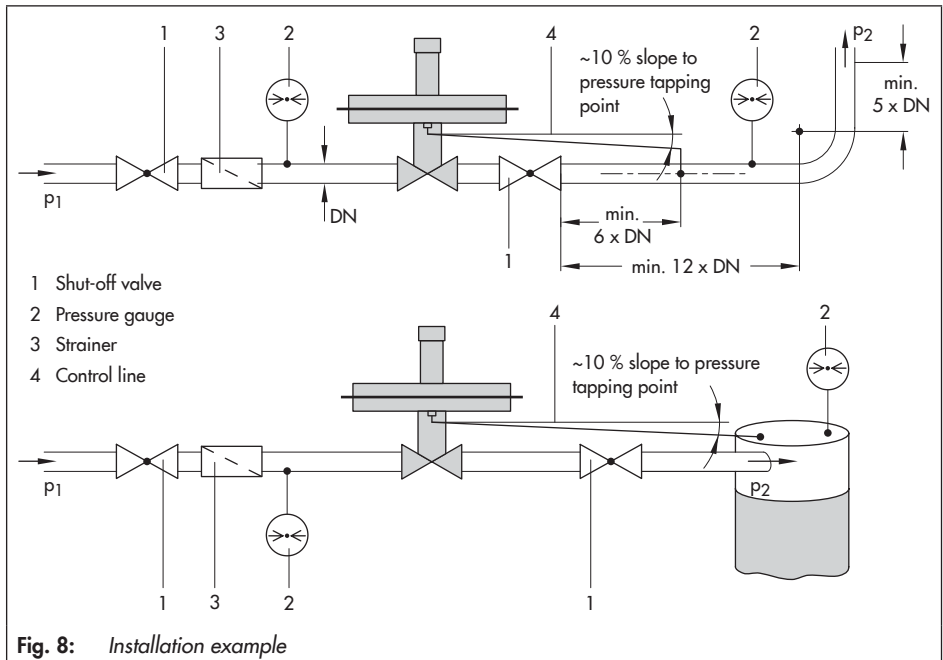

5.1.2 Mounting orientation

Standard

Preferably install the regulator in a horizontal pipeline. The actuator housing with set point adjuster must face upwards.

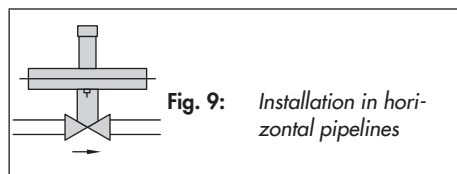

- Install the control line to the tapping point with an approx. 10 % slope to allow any condensing liquid to flow back into the tank or pipe.

Options

Alternatively, the valve can be installed in a vertical pipeline. The actuator housing with set point adjuster must face sideways.

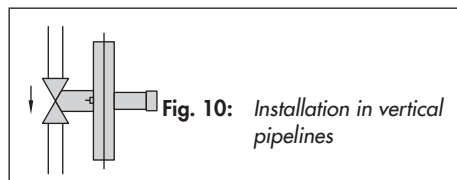

NOTICE

Control deviations due to alternative installation.

System deviations may arise when the regulator is installed in vertical pipelines.

5.1.3 Additional fittings

Strainers

We recommend installing a strainer (e.g. SAMSON Type 2 N) upstream of the regulator. It prevents solid particles in the process medium from damaging the valve.

- Install the strainer upstream of the temperature regulator. The arrow on the valve indicates the direction of flow.
- For installation in vertical pipeline: install the strainer with the filter element facing downwards.
- Install the filter with sufficient space available to remove the filter.
- Check the strainer at regular intervals and clean it, if necessary.

Shut-off valves

Install a hand-operated shut-off valve both upstream of the strainer and downstream of the regulator. This allows the plant to be shut down for cleaning and maintenance, and when the plant is not used for longer periods of time.

Pressure gauges

Install a pressure gauge both upstream and downstream of the regulator to monitor the pressures prevailing in the plant.

Control line

Fitting with G 1/4 female thread (9) on the actuator housing. Route the control line on site preferably using a 6 mm or 1/4" (stainless) steel pipe.

Always connect the control line connection for pressure tapping (see Fig. 8) directly to the tank or vessel as the medium is in the expanded state and no turbulence occurs at this point.

If the pressure is to be tapped at a straight pipeline section, the largest possible distance to the regulator must be kept (at least $6 \times \text{DN}$). Connect the control line at the side or on top of the horizontally running main pipeline. If possible, place the point of pressure tapping in a pipe expansion.

Install any pipe fittings (e.g. restrictions, bends, manifolds or branches), that may cause turbulence in the flow, sufficiently far away from the control line connection (at least $6 \times \text{DN}$).

Optionally, a ready-mounted control line is available for set point ranges 0.8 to 2.5 bar, 2 to 5 bar and 4.5 to 10 bar. This option must be specified in the order (see Fig. 11).

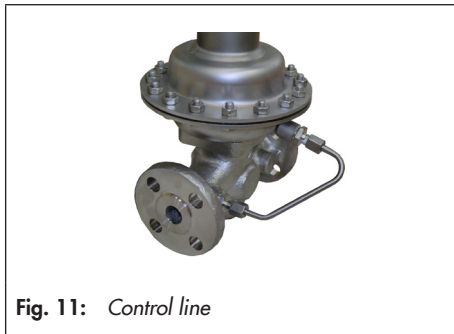

Fig. 11: Control line

NOTICE

Regulator damage due to condensed water. In applications in which the gas can liquefy, condensate may form in the control line, causing damage to the regulator. To allow condensate to run back into the tank, install the control line with an approximate 10 % slope to the pressure tapping point at the tank or pipeline (see Fig. 8).

Leakage line connection

The regulator in the special version is delivered with a leakage line connection. In this version, the opening to the set point adjustment is additionally sealed by a cap.

Connect the leakage line to the G $\frac{1}{4}$ female thread fitting on top of the actuator housing. In the event of a defective diaphragm (diaphragm rupture) in the actuator, any process medium that escapes is fed through a leakage line to a safe location.



Fig. 12: Leakage line connection G $\frac{1}{4}$

5.2 Quick check

Shipping lock

Before testing and start-up, remove the shipping lock, if mounted.

1. Remove the cap (50).
2. Use an open-end wrench (A/F 13) to unscrew the shipping lock screw (223) and remove the shipping lock washer (222).
3. Remount the cap (50).

Pressure test

A pressure test of the plant with the regulator already installed is only permissible up to the nominal pressure of the valve (see Table 1). The pressure at the operating diaphragm must not exceed the maximum permissible pressure. If this cannot be guaranteed, proceed as follows: unscrew the control line at the actuator and seal the open control line. In case pressure surges are expected to occur during start-up or during operation, install a regulator with integrated force limiter (special version, see Table 1).

All plant components must be designed for the test pressure.

5.3 Putting the regulator into operation

1. Make sure the shipping lock has been removed.
2. Make sure the control line is correctly connected and free of dirt. The cross-sectional area of flow must be open.
3. Slowly open the shut-off valves on the upstream pressure side.

4. Open all the valves on the consumer side (downstream of the regulator). Avoid pressure surges.

5.4 Adjusting the set point

The regulator in the delivered state does not have a defined pressure set point. The set point spring is relieved of tension. The set point must be adjusted on starting up the plant.

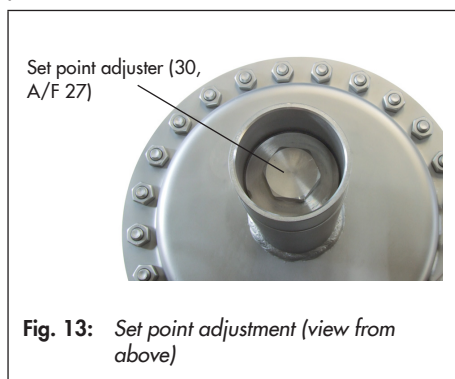

Fig. 13: Set point adjustment (view from above)

Adjust the required set point (see Fig. 13) by tensioning the set point springs (27) at the set point adjuster (30) using a suitable socket wrench (width across flats 27).

1. Remove the cap (50).
2. Use a socket wrench (A/F 27) to turn the set point adjuster (30).
Turn clockwise (↻) to increase the pressure set point (the downstream pressure increases).
Turn counterclockwise (↺) to reduce the pressure set point (the downstream pressure drops).
3. Remount the cap (50).

NOTICE

Incorrect control due to a set point adjuster being turned too far.

If the set point adjuster is turned too far, the regulator becomes blocked and closed-loop control is no longer possible.

Only screw the set point adjuster up to the point where the spring tension can still be felt.

The pressure gauge (Fig. 8) installed on the downstream side on site allows the adjusted set point to be monitored.

6 Servicing

The regulators do not require much maintenance. Nevertheless, they are subject to natural wear, particularly at the seat, plug and operating diaphragm.

⚠ DANGER

Risk of bursting in pressure equipment.

Valves and pipelines are pressure equipment. Improper opening can lead to valve components bursting.

- *Before starting any work on the valve, depressurize all plant sections affected as well as the valve.*
- *Drain the process medium from the plant sections affected as well as from the valve.*
- *Wear personal protective equipment.*

⚠ WARNING

Risk of personal injury due to residual process medium in the valve.

While working on the valve, residual medium can flow out of the valve and, depending on its properties, cause personal injury, e.g. (chemical) burns.

- *If possible, drain the process medium from the plant sections affected and from the valve.*
- *Wear protective clothing, safety gloves and eye protection.*

⚠ WARNING

Risk of burn injuries due to hot or cold components and pipelines.

Depending on the process medium, valve components and pipelines may get very hot or cold and cause burn injuries.

- Allow components and pipelines to cool down or warm up to the ambient temperature.*
 - Wear protective clothing and safety gloves.*
-

i Note

The device was checked by SAMSON before it left the factory.

- Certain test results certified by SAMSON lose their validity when the valve is opened. Such testing includes seat leakage and leak tests.*
 - The product warranty becomes void if service or repair work not described in these instructions is performed without prior agreement by SAMSON's After-sales Service.*
 - Only use original spare parts by SAMSON, which comply with the original specifications.*
-

6.1 Preparation for return shipment

Defective valves can be returned to SAMSON for repair.

Proceed as follows to return devices to SAMSON:

1. Put the control valve out of operation (see Chapter 8).
2. Mount the shipping lock, if necessary.
3. Decontaminate the valve. Remove any residual process medium.
4. Fill in the Declaration on Contamination. The declaration form can be downloaded from our website at
▶ www.samsongroup.com > SERVICE > After Sales Service.
5. Continue as described on our website at
▶ www.samsongroup.com > Service > After-sales Service > Returning goods.

6.2 Ordering spare parts and operating supplies

Contact your nearest SAMSON subsidiary or SAMSON's After-sales Service for information on spare parts, lubricants and tools.

7 Malfunctions

Depending on the operating conditions, check the regulator at certain intervals to prevent possible failure before it can occur. Plant operators are responsible for drawing up an inspection and test plan.



Tip

SAMSON's After-sales Service can support you in drawing up an inspection and test plan for your plant.

7.1 Troubleshooting

Malfunction	Possible reasons	Recommended action
Pressure fluctuations and vibrations	Pressure tapping incorrectly routed.	Check the pressure tapping of the control line (see Chapter 5.1.3 on „Control line“). If necessary, relocate the point of tapping.
	Insufficient throttling.	Screw SAMSON Venturi nozzle into the fitting for the control line connection (9). Order no.: 1991-7114 for A =1200 or 640 cm ² 1991-7113 for A =320 or 160 cm ²
	Improper sizing of the regulator.	Check the sizing data used for the regulator. If necessary, change the K_{VS} coefficient, seat diameter or actuator area.

i Note

Contact SAMSON's After-sales Service for malfunctions not listed in the table.

8 Decommissioning and removal

DANGER

Risk of bursting in pressure equipment.

Valves and pipelines are pressure equipment. Improper opening can lead to bursting of the valve.

- Before starting any work on the control valve, depressurize all plant sections affected as well as the valve.
 - Drain the process medium from the plant sections affected as well as from the valve.
 - Wear personal protective equipment.
-

WARNING

Risk of personal injury due to residual process medium in the valve.

While working on the valve, residual medium can flow out of the valve and, depending on its properties, cause personal injury, e.g. (chemical) burns.

Wear protective clothing, safety gloves and eye protection.

WARNING

Risk of burn injuries due to hot or cold components and pipeline.

Valve components and the pipeline may become very hot or cold. Risk of burn injuries.

- Allow components and pipelines to cool down or warm up to the ambient temperature.
 - Wear protective clothing and safety gloves.
-

8.1 Decommissioning

To decommission the control valve for service and repair work or disassembly, proceed as follows:

1. Close the shut-off valve on the upstream side.
2. Close the shut-off valve on the downstream side.
3. Completely drain the pipelines and valve.
4. Depressurize the plant.
5. If necessary, allow the pipeline and regulator components to cool down or warm up to the ambient temperature.

8.2 Removing the valve from the pipeline

1. Put the regulator out of operation (see Chapter 8.1).
2. Mount the shipping lock, if necessary.
3. Unbolt the flanged joint.
4. Remove the valve from the pipeline.

9 Disposal

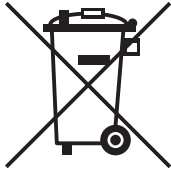

SAMSON is a producer registered at the following European institution ► <https://www.ewrn.org/national-registers/national-registers>.
WEEE reg. no.:
DE 62194439/FR 025665

- ➔ Observe local, national and international refuse regulations.
- ➔ Do not dispose of components, lubricants and hazardous substances together with your other household waste.

i Note

SAMSON can provide you with a recycling passport according to PAS 1049 on request. Simply e-mail us at aftersalesservice@samsongroup.com giving details of your company address.

💡 Tip

On request, SAMSON can appoint a service provider to dismantle and recycle the product as part of a distributor take-back scheme.

- ➔ Observe local, national and international refuse regulations.
- ➔ Do not dispose of components, lubricants and hazardous substances together with your household waste.

10 Appendix

10.1 After-sales service

Contact SAMSON's After-sales Service for support concerning service or repair work or when malfunctions or defects arise.

E-mail

You can reach our after-sales service at aftersalesservice@samsongroup.com.

Addresses of SAMSON AG and its subsidiaries

The addresses of SAMSON AG, its subsidiaries, representatives and service facilities worldwide can be found on our website (www.samsongroup.com) or in all SAMSON product catalogs.

Required specifications

Please submit the following details:

- Order number and position number in the order
- Type, model number, nominal size and valve version
- Upstream and downstream pressure
- Temperature and process medium
- Min. and max. flow rate in m³/h
- Is a strainer installed?
- Installation drawing showing the exact location of the regulator and all the additionally installed components (shut-off valves, pressure gauge etc.)

11 Certificates

The EU and UKCA declarations of conformity are included on the next pages:

- EU declaration of conformity in compliance with Pressure Equipment Directive 2014/68/EU on page 33.
- EU declaration of conformity in compliance with Machinery Directive 2006/42/EC for Type 2405 Regulator on page 39.
- UKCA declaration of conformity in compliance with Directive 2016 No. 1105 on page 40.
- UKCA declaration of conformity in compliance with Directive 2008 No. 1597 for Type 2405 Regulator on page 42.

11.1 Information on the UK sales region

The following information corresponds to the Pressure Equipment (Safety) Regulations 2016, STATUTORY INSTRUMENTS, 2016 No. 1105 (UKCA marking). It does not apply to Northern Ireland.

Importer

SAMSON Controls Ltd
Perrywood Business Park
Honeycrock Lane
Redhill, Surrey RH1 5JQ
Phone: +44 1737 766391
E-mail: sales-uk@samsongroup.com
Website: uk.samsongroup.com

EU DECLARATION OF CONFORMITY
TRANSLATION



Module A

For the following products, SAMSON hereby declares under its sole responsibility:

Devices	Series	Type	Version
Self-operated Regulators	43	2432	DIN EN, body, CC499K and EN-GJS-400-18-LT, DN 50, PN 25, fluids G2, L2, L1 ¹⁾
	43	2436	DIN EN, body, CC499K and EN-GJS-400-18-LT, DN 50, PN 25, fluids G2, L2, L1 ¹⁾
	43	2437	DIN EN, body, CC499K and EN-GJS-400-18-LT, DN 50, PN 25, fluids G2, L2, L1 ¹⁾
	---	2111	DIN EN, body, EN-GJS-400-18-LT, DN 50, PN 25, fluids G2, L2, L1 ¹⁾ DIN EN, body, 1.0619 and 1.4408, DN 40-50, PN 40, fluids G2, L2, L1 ¹⁾ ANSI, body, A216 WCC and A351 CF8M, NPS 1½-2, Class 300, fluids G2, L2, L1 ¹⁾
Three-way valve	---	2119	DIN EN, body, EN-GJL-250 and 1.0619, DN 65-125, PN 16, fluids G2, L2, L1 ¹⁾
			DIN EN, body, 1.0619, DN 50-80, PN 25, fluids G2, L2, L1 ¹⁾
			DIN EN, body, 1.0619 and 1.4408, DN 40-50, PN 40, fluids G2, L2, L1 ¹⁾
			ANSI, body, A216 WCC and A351 CF8M, NPS 2½-4, Class 150, fluids G2, L2, L1 ¹⁾ ANSI, body, A216 WCC and A351 CF8M, NPS 1½, Class 300, fluids G2, L2, L1 ¹⁾
Control valve	---	3222	DIN EN, body, EN-GJS-400-18-LT, DN 50, PN 25, fluids G2, L2, L1 ¹⁾ DIN EN, body, CC499K, DN 32-40, PN 25, all fluids
Three-way valve	---	3226	DIN EN, body, CC499K, DN 50, PN 25, fluids G2, L2 ²⁾
Three-way valve	---	3260	DIN EN, body, EN-GJL-250, DN 65-200, PN 16, fluids G2, L2 ²⁾
Globe valve Three-way valve	V2001	3531	DIN EN, body, EN-GJS-400-18-LT, DN 50-80, PN 25, fluids G2, L2, L1 ¹⁾
		3535	DIN EN, body, 1.0619 and 1.4408, DN 32-40, PN 25, all fluids ANSI, body, A216 WCC and A351 CF8M, NPS 1½-2, Class 150, all fluids
Control valve	---	3214	DIN EN, body, EN-GJL-250, DN 65-125, PN 16, fluids G2, L2, L1 ¹⁾
			DIN EN, body, EN-GJS-400-18-LT, DN 50-80, PN 25, fluids G2, L2, L1 ¹⁾ ANSI, body, A126 B, NPS 3-4, Class 125, fluids G2, L2, L1 ¹⁾ ANSI, body, A216 WCC and A351 CF8M, NPS 1½-2, Class 150, all fluids
Self-operated Regulators	42	2423	DIN EN, body, EN-GJL-250 and EN-GJS-400-18-LT, DN 65-125, PN 16, fluids G2, L2, L1 ¹⁾
			DIN EN, body, EN-GJS-418-LT, DN 50-80, PN 25, fluids G2, L2, L1 ¹⁾
			DIN EN, body, 1.0619 and 1.4408, DN 32-50, PN 16, all fluids DIN EN, body, 1.0619 and 1.4408, DN 32-40, PN 25, all fluids ANSI, body, A126 B, NPS 3-4, Class 125, fluids G2, L2, L1 ¹⁾ ANSI, body, A216 WCC and A351 CF8M, NPS 1½-2, Class 150, all fluids
	42	2422	DIN EN, body, EN-GJL-250 and EN-GJS-400-18-LT, DN 65-125, PN 16, fluids G2, L2, L1 ¹⁾
			DIN EN, body, EN-GJS-400-18-LT, DN 50-80, PN 25, fluids G2, L2, L1 ¹⁾
			DIN EN, body, 1.0619, 1.4408 and 1.6220-OT, DN 32-50, PN 16, all fluids ANSI, body, A126 B, NPS 3-4, Class 125, fluids G2, L2, L1 ¹⁾ ANSI, body, A216 WCC, A351 CF8M and A352 LCC, NPS 1½-2, Class 150, all fluids
Strainers	1N/1N1	2601	DIN EN, body, CB752S, G 2 (DN50), PN25, fluids G2, L2 ²⁾
Strainers	2N/2N1	2602	DIN EN, body, EN-GJL-250, DN 200-250, PN 10, fluids G2, L2, L1 ¹⁾
			DIN EN, body, EN-GJL-250, DN 65-125, PN 16, fluids G2, L2, L1 ¹⁾
			DIN EN, body, EN-GJS-400-18-LT, DN 100-125, PN 16, fluids G2, L2, L1 ¹⁾
			DIN EN, body, EN-GJS-400-18-LT, DN 50-80, PN 25, fluids G2, L2, L1 ¹⁾ DIN EN, body, 1.4408, DN 32-50, PN 16, all fluids
Self-operated Regulators	44	2373/2375	ANSI, body, A995 4A and A995 5A, NPS 1½-2, Class 150, all fluids
		2440 (44-0B) 2441 (44-1B) 2446 (44-6B)	DIN EN, body, EN-GJS-400-18-LT, DN 50, PN 25, fluids G2, L2, L1 ¹⁾
		2442 (44-2) 2443 (44-3) 2444 (44-4) 2447 (44-7) 2449 (44-9)	DIN EN, body, EN-GJS-400-18-LT and CC499K, DN 50, PN 25, fluids G2, L2, L1 ¹⁾

Revision 01

Classification: Public · SAMSON AKTIENGESELLSCHAFT · Weismuellerstrasse 3 · 60314 Frankfurt am Main, Germany

Page 1 of 3

EU DECLARATION OF CONFORMITY
TRANSLATION



Devices	Series	Type	Version	
Self-operated Regulators	45	2451 (45-1)	DIN EN, body, EN-GJS-400-18-LT and CC499K, DN 50, PN 25, fluids G2, L2, L1 ¹⁾	
		2452 (45-2)		
		2453 (45-3)		
		2454 (45-4)		
		2459 (45-9)		
	46	2465 (46-5)	DIN EN, body, EN-GJS-400-18-LT and CC499K, DN 50, PN 25, fluids G2, L2, L1 ¹⁾	
		2466 (46-6)		
		2467 (46-7)		
		2469 (46-9)		
	47	2471 (47-1)	DIN EN, body, EN-GJS-400-18-LT and CC499K, DN 50, PN 25, fluids G2, L2, L1 ¹⁾	
		2474 (47-4)		
		2475 (47-5)		
		2479 (47-9)		
		2488		
	40	2405	DIN EN, body, EN-GJS-400-18-LT, DN 50, PN 25, fluids G2, L2, L1 ¹⁾	
			ANSI, body, A216 WCC and A351 CF8M, NPS 1½-2, Class 150, all fluids	
		2406	DIN EN, body, EN-GJL-250, DN 65-125, PN 16, fluids G2, L2, L1 ¹⁾	
			DIN EN, body, EN-GJS-400-18-LT, DN 50, PN 25, fluids G2, L2, L1 ¹⁾	
			ANSI, body, A126 B, NPS 3-4, Class 125, fluids G2, L2, L1 ¹⁾	
			ANSI, body, A216 WCC and A351 CF8M, NPS 1½-2, Class 150, all fluids	
			DIN EN, body, EN-GJL-250, DN 65-100, PN 16, fluids G2, L2, L1 ¹⁾	
			DIN EN, body, EN-GJS-400-18-LT, DN 50-80, PN 25, fluids G2, L2, L1 ¹⁾	
		41	2412 2417	ANSI, body, A126 B, NPS 3-4, Class 125, fluids G2, L2, L1 ¹⁾
				ANSI, body, A216 WCC and A351 CF8M, NPS 1½-2, Class 150, all fluids
		42	2421 RS	DIN EN, body, 1.0619, 1.4408, 1.4571 and 1.4401/1.4404, DN 32-50, PN 16, all fluids
				DIN EN, body, 1.0619, 1.4408, 1.4571 and 1.4401/1.4404, DN 32-40, PN 25, all fluids
	---	2331	ANSI, body, A216 WCC, A351 CF8M and A182 F316/A182 F316L, NPS 1½-2, Class 150, all fluids	
			DIN EN, body, EN-GJL-250, DN 65-200, PN 16, fluids G2, L2 ²⁾	
DIN EN, body, EN-GJS-400-18-LT, DN 65-150, PN 16, fluids G2, L2 ²⁾				
DIN EN, body, EN-GJS-400-18-LT, DN 65-125, PN 25, fluids G2, L2 ²⁾				
DIN EN, body 1.0619, DN 65-200, PN 16, fluids G2, L2 ²⁾				
---	2337	DIN EN, body 1.0619, DN 65-100, PN 40, fluids G2, L2 ²⁾		
		DIN EN, body 1.0619, DN 250, PN 25, fluids L1 ¹⁾		
---	2333 2335	DIN EN, body 1.0619, DN 250, PN 40, fluids L1 ¹⁾		
		DIN EN, body, EN-GJL-250, DN 65-125, PN 16, fluids G2, L2, L1 ¹⁾		
		DIN EN, body, EN-GJS-400-18-LT, DN 65-80, PN 25, fluids G2, L2, L1 ¹⁾		
---	2334	ANSI, body, A126 B, NPS 3-4, Class 125, fluids G2, L2, L1 ¹⁾		
		DIN EN, body, EN-GJL-250, DN 65-125, PN 16, fluids G2, L2, L1 ¹⁾		
		DIN EN, body, EN-GJS-400-18-LT, DN 65-125, PN 16, fluids G2, L2, L1 ¹⁾		
		DIN EN, body, EN-GJS-400-18-LT, DN 65-80, PN 25, fluids G2, L2, L1 ¹⁾		
---	2404-1	ANSI, body, A126 B, NPS 3-4, Class 125, fluids G2, L2, L1 ¹⁾		
		DIN EN, body, EN-GJL-250, DN 65-125, PN16, fluids G2, L2, L1 ¹⁾		
---	2404-2	ANSI, body, A216 WCC und A351 CF8M, NPS 1½-2, Class 150, all fluids		
		DIN EN, body, EN-GJL-250, DN 65-125, PN 16, fluids G2, L2, L1 ¹⁾		
		ANSI, body, A126 B, NPS 3-4, Class 125, fluids G2, L2, L1 ¹⁾		

¹⁾ Gases according to Article 4(1)(c.i), second indent
Liquids according to Article 4(1)(c.ii)

²⁾ Gases according to Article 4(1)(c.i), second indent
Liquids according to Article 4(1)(c.ii), second indent

Revision 01

EU DECLARATION OF CONFORMITY
TRANSLATION



That the products mentioned above comply with the requirements of the following standards:

Directive of the European Parliament and of the Council on the harmonization of the laws of the Member States relating to the making available on the market of pressure equipment	2014/68/EU	of 15. May 2014
Applied conformity assessment procedure for fluids according to Article 4(1)	Module A	

Technical standards applied: DIN EN 12516-2, DIN EN 12516-3, ASME B16.34

Manufacturer: SAMSON AG, Weismüllerstraße 3, 60314 Frankfurt am Main, Germany

Frankfurt am Main, 05. June 2024

ppc. C. Tollas

ppc. Norbert Tollas
Senior Vice President
Global Operations

i.v. P. Scheermesser

i.V. Peter Scheermesser
Director
Product Maintenance & Engineered Products

Revision 01

EU DECLARATION OF CONFORMITY
TRANSLATION



Module H / N° CE-0062-PED-H-SAM 001-22-DEU-rev-A

For the following products, SAMSON hereby declares under its sole responsibility:

Devices	Series	Type	Version
Three-way valve	---	2119	DIN EN, body, EN-GJL-250 and 1.0619, DN 150, PN 16, fluids G2, L2, L1 ¹⁾
			DIN EN, body, 1.0619, DN 100-150, PN 25, fluids G2, L2, L1 ¹⁾
			DIN EN, body, 1.0619 and 1.4408, DN 65-150, PN 40, fluids G2, L2, L1 ¹⁾
			ANSI, body, A216 WCC and A351 CF8M, NPS 6, Class 150, fluids G2, L2, L1 ¹⁾
			ANSI, body, A216 WCC and A351 CF8M, NPS 2-6, Class 300, fluids G2, L2, L1 ¹⁾
Self-operated Regulators	---	3222	DIN EN, body, CC499K, DN 50, PN 25, all fluids
Three-way valve	---	3260	DIN EN, body, EN-GJL-250, DN 250-300, PN 16, fluids G2, L2 ¹⁾
Globe valve Three-way valve	V2001	3531	DIN EN, body, 1.0619 and 1.4408, DN 50-80, PN 25, all fluids
		3535	ANSI, body, A216 WCC and A351 CF8M, NPS 2½-3, Class 150, all fluids
Control valve	---	3214	DIN EN, body, EN-GJL-250, DN 150-400, PN 16, fluids G2, L2, L1 ¹⁾
			DIN EN, body, EN-GJS-400-18-LT, DN 100-150, PN 25, fluids G2, L2, L1 ¹⁾
			DIN EN, body, 1.0619, DN 32-400, PN 40, all fluids
			ANSI, body, A126 B, NPS 6-10, Class 125, fluids G2, L2, L1 ¹⁾
			ANSI, body, A216 WCC, NPS 2½-10, Class 150, all fluids
Self-operated Regulators	42	2423	ANSI, body, A216 WCC, NPS 1½-10, Class 300, all fluids
			DIN EN, body, EN-GJL-250, DN 150-250, PN 16, fluids G2, L2, L1 ¹⁾
			DIN EN, body, EN-GJS-400-18-LT, DN 150, PN 16, fluids G2, L2, L1 ¹⁾
			DIN EN, body, EN-GJS-400-18-LT, DN 100-150, PN 25, fluids G2, L2, L1 ¹⁾
			DIN EN, body, 1.0619 and 1.4408, DN 65-250, PN 16, all fluids
			DIN EN, body, 1.0619 and 1.4408, DN 50-250, PN 25, all fluids
			DIN EN, body, 1.0619 and 1.4408, DN 32-250, PN 40, all fluids
			ANSI, body, A126 B, NPS 6-10, Class 125, fluids G2, L2, L1 ¹⁾
			ANSI, body, A216 WCC and A351 CF8M, NPS 2½-10, Class 150, all fluids
			ANSI, body, A216 WCC and A351 CF8M, NPS 1½-10, Class 300, all fluids
	42	2422	DIN EN, body, EN-GJL-250, DN 150-400, PN 16, fluids G2, L2, L1 ¹⁾
			DIN EN, body, EN-GJS-400-18-LT, DN 100-150, PN 25, fluids G2, L2, L1 ¹⁾
			DIN EN, body, 1.0619 and 1.4408, DN 65-400, PN 16, all fluids
			DIN EN, body, 1.0619 and 1.4408, DN 200-400, PN 25, all fluids
			DIN EN, body, 1.0619 and 1.4408, DN 32-400, PN 40, all fluids
			DIN EN, body, 1.0460, DN 40-50, PN 40, all fluids
			DIN EN, body, 1.6220+QT, DN 65-250, PN 16, all fluids
			DIN EN, body, 1.6220+QT, DN 200-250, PN 25, all fluids
			DIN EN, body, 1.6220+QT, DN 32-250, PN 40, all fluids
			ANSI, body, A126 B, NPS 6-16, Class 125, fluids G2, L2, L1 ¹⁾
42	2421RS	ANSI, body, A216 WCC and A351CF8M, NPS 2½-16, Class 150, all fluids	
		ANSI, body, A216 WCC and A351CF8M, NPS 1½-16, Class 300, all fluids	
		ANSI, body, A105, NPS 1½-2, Class 300, all fluids	
		ANSI, body, A352 LCC, NPS 2½-10, Class 150, all fluids	
		ANSI, body, A352 LCC, NPS 1½-10, Class 300, all fluids	
		DIN EN, body, 1.0619 and 1.4408, DN 65-150, PN 16, all fluids	
		DIN EN, body, 1.0619 and 1.4408, DN 50-150, PN 25, all fluids	
		DIN EN, body, 1.0619 and 1.4408, DN 32-150, PN 40, all fluids	
		DIN EN, body, 1.4571 and 1.4401/1.4404, DN 50, PN 25, all fluids	
		DIN EN, body, 1.4571 and 1.4401/1.4404, DN 32-50, PN 40, all fluids	
ANSI, body, A216 WCC and A351 CF8M, NPS 2½-6, Class 150, all fluids			
ANSI, body, A216 WCC and A351 CF8M, NPS 1½-6, Class 300, all fluids			

Revision 01

EU DECLARATION OF CONFORMITY
TRANSLATION



Devices	Series	Type	Version
Self-operated Regulators	40	2405	DIN EN, body, 1.0619, 1.4571, 1.4404, 1.4408, 1.0460, DN 32-50, PN40, all fluids
			ANSI, body, A105, A182 F316L, A351 CF8M, A216 WCC, NPS 1½-2, Class 300, all fluids
		DIN EN, body, EN-GJL-250, DN 150, PN 16, fluids G2, L2, L1 ¹⁾	
		DIN EN, body, 1.0619 and 1.4408, DN 32-150, PN 40, all fluids	
		DIN EN, body, 1.0460 and 1.4404, DN 32-50, PN 40, all fluids	
		ANSI, body, A126 B, NPS 6, Class 125, fluids G2, L2, L1 ¹⁾	
	41	2412 2417	ANSI, body, A216 WCC and A351 CF8M, NPS 2½-6, Class 150, all fluids
			ANSI, body, A216 WCC and A351 CF8M, NPS 1½-6, Class 300, all fluids
			ANSI, body, A105 and A182 F316L, NPS 1½-2, Class 300, all fluids
			DIN EN, body, EN-GJS-400-18-LT, DN 100, PN25, fluids G2, L2, L1 ¹⁾
			DIN EN, body, 1.0619 and 1.4408, DN 32-100, PN 40, all fluids
			DIN EN, body, 1.0460, 1.4571 and 1.4404, DN 32-80, PN 40, all fluids
	---	2404-1	ANSI, body, A216 WCC and A351 CF8M, NPS 2½-4, Class 150, all fluids
			ANSI, body, A216 WCC and A351 CF8M, NPS 1½-4, Class 300, all fluids
			ANSI, body, A105 and A182 F316L, NPS 1½-3, Class 300, all fluids
			DIN EN, body, EN-GJL-250, DN 150, PN16, fluids G2, L2, L1 ¹⁾
			DIN EN, body, 1.0619 und 1.4408, DN 32-150, PN 40, all fluids
			ANSI, body, A126 B, NPS 6, Class 125, fluids G2, L2, L1 ¹⁾
	---	2404-2	ANSI, body, A216 WCC und A351 CF8M, NPS 1½-6, Class 300, all fluids
			ANSI, body, A216 WCC und A351 CF8M, NPS 2½-10, Class 300, all fluids
			DIN EN, body, EN-GJL-250, DN 150-400, PN 16, fluids G2, L2, L1 ¹⁾
			DIN EN, body, 1.0619 und 1.4408, DN 65-400, PN 16, all fluids
			DIN EN, body, 1.0619 und 1.4408, DN 65-400, PN 40, all fluids
			ANSI, body, A126 B, NPS 6-16, Class 125, fluids G2, L2, L1 ¹⁾
	---	2331	ANSI, body, A216 WCC und A351 CF8M, NPS 2½-16, Class 150, all fluids
			ANSI, body, A216 WCC und A351 CF8M, NPS 2½-10, Class 300, all fluids
			DIN EN, body, EN-GJL-250, DN 250, PN 16, fluids G2, L2 ¹⁾
			DIN EN, body, 1.0619, DN 250, PN 16, fluids G2, L2 ¹⁾
			DIN EN, body, 1.0619, DN 200-250, PN 25, fluids G2, L2 ¹⁾
			DIN EN, body, 1.0619, DN 125-250, PN 40, fluids G2, L2 ¹⁾
---	2333 2335	DIN EN, body, EN-GJL-250, DN 150-400, PN 16, fluids G2, L2, L1 ¹⁾	
		DIN EN, body, EN-GJS-400-18-LT, DN 100-150, PN 25, fluids G2, L2, L1 ¹⁾	
		DIN EN, body, 1.0619 and 1.4408, DN 65-400, PN 16, all fluids	
		DIN EN, body, 1.0619 and 1.4408, DN 200-400, PN 25, all fluids	
		DIN EN, body, 1.0619 and 1.4408, DN 65-400, PN 40, all fluids	
		ANSI, body, A126 B, NPS 6-16, Class 125, fluids G2, L2, L1 ¹⁾	
---	2334	ANSI, body, A216 WCC and A351 CF8M, NPS 2½-16, Class 150, all fluids	
		ANSI, body, A216 WCC and A351 CF8M, NPS 2½-16, Class 300, all fluids	
		DIN EN, body, EN-GJL-250, DN 150-400, PN 16, fluids G2, L2, L1 ¹⁾	
		DIN EN, body, EN-GJS-400-18-LT, DN 150, PN 16, fluids G2, L2, L1 ¹⁾	
		DIN EN, body, EN-GJS-400-18-LT, DN 100-150, PN 25, fluids G2, L2, L1 ¹⁾	
		DIN EN, body, 1.0619 and 1.4408, DN 65-400, PN 16, all fluids	
---	2373 2375	DIN EN, body, 1.0619 and 1.4408, DN 200-400, PN 25, all fluids	
		DIN EN, body, 1.0619 and 1.4408, DN 65-400, PN 40, all fluids	
		ANSI, body, A126 B, NPS 6-16, Class 125, fluids G2, L2, L1 ¹⁾	
		ANSI, body, A216 WCC and A351 CF8M, NPS 2½-16, Class 150, all fluids	
		ANSI, body, A216 WCC and A351 CF8M, NPS 2½-16, Class 300, all fluids	
		DIN EN, body, 1.4469 and 1.4470, DN 32-50, PN 40, all fluids	
Strainers	2N/2NI	2602	ANSI, body, A995 5A and A995 4A, NPS 1½-2, Class 300, all fluids
			DIN EN, body, EN-GJL-250, DN 150-250, PN 16, fluids G2, L2, L1 ¹⁾
			DIN EN, body, EN-GJS-400-18-LT, DN 150, PN 16, fluids G2, L2, L1 ¹⁾
			DIN EN, body, EN-GJS-400-18-LT, DN 100-150, PN 25, fluids G2, L2, L1 ¹⁾
DIN EN, body, 1.0619, DN 100-250, PN 16, all fluids			

Revision 01

Classification: Public · SAMSON AKTIENGESELLSCHAFT · Weismuellerstrasse 3 · 60314 Frankfurt am Main, Germany

Page 2 of 3

EU DECLARATION OF CONFORMITY
TRANSLATION



Devices	Series	Type	Version
Strainers	2N/2NI	2602	DIN EN, body, 1.0619, DN 200-250, PN 25, all fluids
			DIN EN, body, 1.0619, DN 32-250, PN 40, all fluids
			DIN EN, body, 1.4408, DN 65-100, PN 16, all fluids
			DIN EN, body, 1.4408, DN 32-100, PN 40, all fluids

¹⁾ Gases according to Article 4(1)(c.i), second indent
Liquids according to Article 4(1)(c.ii)

That the products mentioned above comply with the requirements of the following standards:

Directive of the European Parliament and of the Council on the harmonization of the laws of the Member States relating to the making available on the market of pressure equipment	2014/68/EU	of 15. May 2014
Applied conformity assessment procedure for fluids according to Article 4(1)	Module H	by Bureau Veritas 0062

The manufacturer's quality management system is monitored by the following notified body:
Bureau Veritas Services SAS, 4 place des Saisons, 92400 Courbevoie, France
Technical standards applied: DIN EN 12516-2, DIN EN 12516-3, ASME B16.34

Manufacturer: SAMSON AG, Weismuellerstrasse 3, 60314 Frankfurt am Main, Germany

Frankfurt am Main, 05. June 2024

ppa. Norbert Tollas
Senior Vice President
Global Operations

i.V. Peter Scheermesser
Director
Product Maintenance & Engineered Products

Revision 01

EU DECLARATION OF CONFORMITY
TRANSLATION



Declaration of Conformity of Final Machinery

in accordance with Annex II, section 1.A. of the Directive 2006/42/EC

For the following products:

Type 2405 Pressure Reducing Valve

We hereby declare that the machinery mentioned above complies with all applicable requirements stipulated in Machinery Directive 2006/42/EC.

For product descriptions of the valve and actuator, refer to:

- Type 2405 Pressure Reducing Valve: Mounting and Operating Instructions EB 2520

Referenced technical standards and/or specifications:

- VCI, VDMA, VGB: "Leitfaden Maschinenrichtlinie (2006/42/EG) – Bedeutung für Armaturen, Mai 2018" [German only]
- VCI, VDMA, VGB: "Zusatzdokument zum Leitfaden Maschinenrichtlinie (2006/42/EG) – Bedeutung für Armaturen vom Mai 2018" [German only], based on DIN EN ISO 12100:2011-03

Comment:

Information on residual risks of the machinery can be found in the mounting and operating instructions of the valve and actuator as well as in the referenced documents listed in the mounting and operating instructions.

Persons authorized to compile the technical file:
SAMSON AG, Weismüllerstraße 3, 60314 Frankfurt am Main, Germany
Frankfurt am Main, 20 September 2021

Stephan Giesen
Director
Product Management

Peter Scheermesser
Director
Product Life Cycle Management and ETO
Development for Valves and Actuators

Revision no. 00

Classification: Public · SAMSON AKTIENGESELLSCHAFT · Weismüllerstraße 3 · 60314 Frankfurt, Germany

Page 1 of 1

**UK
CA** UK DECLARATION OF CONFORMITY
ORIGINAL



**The Pressure Equipment (Safety) Regulations 2016
Module A**

For the following products, SAMSON hereby declares under its sole responsibility:

Devices	Type	Version
Self-operated Regulators	2405	DIN EN, body, EN-GJS-400-18-LT, DN 50, PN 25, fluids G2, L2, L1 ¹⁾ ANSI, body, A216 WCC and A351 CF8M, NPS 1½-2, Class 150, all fluids

¹⁾ Gases according to Article 4(1)(c.i), second indent // Liquids according to Article 4(1)(c.ii) acc. to PE(S)R 2016

The object of the declaration described above is in conformity with the relevant Union harmonization legislation:

Legislation: STATUTORY INSTRUMENTS – 2016 No. 1105 – CONSUMER PROTECTION HEALTH AND SAFETY – The Pressure Equipment (Safety) Regulations 2016	PE(S)R 2016
Applied conformity assessment procedure for fluids according to Article 4(1)	Module A

Technical standards applied: EN 12516-2, EN 12516-3;
Other technical standards applied: ASME B16.34

Manufacturer:
SAMSON AKTIENGESELLSCHAFT, Weismüllerstraße 3, 60314 Frankfurt am Main, Germany
Frankfurt am Main, 8th November 2022

ppc. G. Tollas

Norbert Tollas
Senior Vice President
Global Operations

i. V. P. Scheermesser

Peter Scheermesser
Director
Product Maintenance & Engineered Products

Revision 00

Classification: Public · SAMSON AKTIENGESELLSCHAFT · Weismüllerstrasse 3 · 60314 Frankfurt am Main, Germany Page 1 of 1

UK UK DECLARATION OF CONFORMITY
CA ORIGINAL



**The Pressure Equipment (Safety) Regulations 2016
 Module H / N° CE-0062-PED-H-SAM 001-22-DEU**

For the following products, SAMSON hereby declares under its sole responsibility:

Devices	Type	Version
Self-operated Regulators	2405	DIN EN, body, 1.0619, 1.4571, 1.4404, 1.4408, 1.0460, DN 32-50, PN40, all fluids ANSI, body, A105, A182 F316L, A351 CF8M, A216 WCC, NPS 1½-2, Class 300, all fluids

The object of the declaration described above is in conformity with the relevant Union harmonization legislation:

Legislation: STATUTORY INSTRUMENTS – 2016 No. 1105 – CONSUMER PROTECTION HEALTH AND SAFETY – The Pressure Equipment (Safety) Regulations 2016	PE(S)R 2016	2022
Applied conformity assessment procedure for fluids according to Article 4(1)	Module H	Certificate-No.: N°CE-0062-PED-H-SAM 001-22-DEU by Bureau Veritas 0062

The manufacturer's quality management system is monitored by the following approved body:
Bureau Veritas Services SAS, 8 Cours du Triangle, 92800 PUTEAUX – LA DEFENSE (No. 0062)
 Designated Standards applied: EN 12516-2, EN 12516-3;
 Other technical standards applied: ASME B16.34

Manufacturer:
SAMSON AKTIENGESELLSCHAFT, Weismüllerstraße 3, 60314 Frankfurt am Main, Germany
 Frankfurt am Main, 8th November 2022

ppc. C. Tollas

 Norbert Tollas
 Senior Vice President
 Global Operations

i. v. P. Scheermesser

 Peter Scheermesser
 Director
 Product Maintenance & Engineered Products



UK DECLARATION OF CONFORMITY
ORIGINAL



Declaration of Conformity of Final Machinery

in accordance with Schedule 2 Part 2 Annex II, section 1.A. of the Directive 2008 No. 1597 Supply of Machinery (Safety) Regulations 2008

For the following products:

Type 2405 Pressure Reducing Valve

We hereby declare that the machinery mentioned above complies with all applicable requirements stipulated in Directive 2008 No. 1597 Supply of Machinery (Safety) Regulations 2008.

For product descriptions, refer to:

- Type 2405 Pressure Reducing Valve: Mounting and Operating Instructions EB 2520

Valve accessories (e.g. positioners, limit switches, solenoid valves, lock-up valves, supply pressure regulators, volume boosters and quick exhaust valves) are classified as machinery components in this declaration of conformity. Machinery components can be mounted onto the above specified final machinery if they comply with the specifications and properties defined by SAMSON Manual H 02 "Appropriate Machinery Components for SAMSON Pneumatic Control Valves with a Declaration of Conformity of Final Machinery".

Referenced technical standards and/or specifications:

- VCI, VDMA, VGB: "Leitfaden Maschinenrichtlinie (2006/42/EG) – Bedeutung für Armaturen, Mai 2018" [German only]
- VCI, VDMA, VGB: "Zusatzdokument zum „Leitfaden Maschinenrichtlinie (2006/42/EG) – Bedeutung für Armaturen vom Mai 2018" [German only], based on DIN EN ISO 12100:2011-03

Comment:

Information on residual risks of the machinery can be found in the mounting and operating instructions of the valve and actuator as well as in the referenced documents listed in the mounting and operating instructions.

Persons authorized to compile the technical file:

SAMSON AG, Weismüllerstraße 3, 60314 Frankfurt am Main, Germany
Frankfurt am Main, 8 November 2022

i.v. [Signature]

Stephan Giesen
Director
Product Management

i. v. P. [Signature]

Peter Scheermesser
Director
Product Maintenance & Engineered Products

Revision 00

EB 2520 EN



SAMSON AKTIENGESELLSCHAFT
Weismüllerstraße 3 · 60314 Frankfurt am Main, Germany
Phone: +49 69 4009-0 · Fax: +49 69 4009-1507
samson@samsongroup.com · www.samsongroup.com