

MOUNTING AND OPERATING INSTRUCTIONS



EB 2560 EN

Translation of original instructions



Type 2357-11 Pressure Build-up Regulator/Type 2357-21 Excess Pressure Valve

Type 2357-11 Pressure Build-up Regulator · Type 2357-21 Excess Pressure Valve

Self-operated Pressure Regulators

Edition August 2024



Note on these mounting and operating instructions

These mounting and operating instructions assist you in mounting and operating the device safely. The instructions are binding for handling SAMSON devices.

- For the safe and proper use of these instructions, read them carefully and keep them for later reference.
- If you have any questions about these instructions, contact SAMSON's After-sales Service (aftersaleservice@samsongroup.com).



The mounting and operating instructions for the devices are included in the scope of delivery. The latest documentation is available on our website at www.samsongroup.com > **Downloads** > **Documentation**.

Definition of signal words

DANGER

Hazardous situations which, if not avoided, will result in death or serious injury

WARNING

Hazardous situations which, if not avoided, could result in death or serious injury

NOTICE

Property damage message or malfunction

Note

Additional information

Tip

Recommended action

1	General safety instructions	4
2	Process medium and scope of application	5
2.1	Transportation and storage	5
3	Design and principle of operation	6
4	Installation	8
4.1	Mounting orientation	8
4.2	Shut-off valve.....	8
5	Operation	9
5.1	Start-up.....	9
5.2	Set point adjustment.....	9
5.3	Changing the set point range.....	9
5.4	Decommissioning	9
6	Servicing	10
6.1	Exchanging the seat and plug	11
6.2	Exchanging the non-return unit	11
7	After-sales service	12
8	Disposal	12
9	Nameplate	13
10	Dimensions and weights	14
11	Technical data	15
12	Certificates	16
12.1	Information on the UK sales region.....	16



1 General safety instructions

- The regulators are to be mounted, started up or serviced by fully trained and qualified personnel only; the accepted industry codes and practices are to be observed. Make sure employees or third parties are not exposed to any danger.
- All safety instructions and warnings given in these mounting and operating instructions, particularly those concerning installation, start-up, and maintenance, must be strictly observed.
- According to these mounting and operating instructions, trained personnel refers to individuals who are able to judge the work they are assigned to and recognize possible dangers due to their specialized training, their knowledge and experience as well as their knowledge of the applicable standards.
- The regulators comply with the requirements of the European Pressure Equipment Directive 2014/68/EU, Machinery Directive 2006/42/EC, Directive 2016 No. 1105 Pressure Equipment (Safety) Regulations 2016 and Directive 2008 No. 1597 Supply of Machinery (Safety) Regulations 2008. Regulators with a CE marking and/or UKCA marking have a declaration of conformity, which includes information about the applied conformity assessment procedure. The declaration of conformity is included in the 'Certificates' chapter.
- To ensure appropriate use, only use the regulator in applications where the operating pressure and temperatures do not exceed the specifications used for sizing the regulator at the ordering stage.
- The manufacturer does not assume any responsibility for damage caused by external forces or any other external factors.
- Any hazards that could be caused in the pressure regulator by the process medium, operating pressure or by moving parts are to be prevented by taking appropriate precautions.
- Proper transport, storage, installation, operation, and maintenance are assumed.

2 Process medium and scope of application

Pressure regulators for cryogenic gases and liquids as well as other liquids, gases and vapors. Operating pressures up to 63 bar, with set points from 1 to 40 bar. Temperature range from -200 to +200 °C. Oxygen clean according to international standards and guidelines.

The regulators are designed to keep the pressure constant to the adjusted set point, especially in cryogenic plants.

! WARNING

Risk of injury and property damage due to high pressure in the plant.

A suitable overpressure protection must be installed on site in the plant section.

2.1 Transportation and storage

The regulators must be carefully handled, transported and stored. Protect the regulators against adverse influences, such as dust, dirt or moisture during storage and transportation before being installed.

In the delivered state, the pressure regulators are packed to be free of oil and grease for oxygen service. To avoid contamination, do not open the packaging until immediately before installation.

3 Design and principle of operation

See Fig. 1 on page 7.

Ports A and B are marked on the valve body.

Type 2357-11 Pressure Build-up Regulator

Functioning as a Type 2357-11 Pressure Build-up Regulator (Fig. 1) with direction of flow from port B to port A, the pressure upstream of the valve (port B) is transmitted to the operating diaphragm. The valve closes when the upstream pressure increases and opens when the upstream pressure drops.

The pressure build-up regulator operates as a safety valve and relieves the pressure chamber of pressure when the pressure exceeds the set point by 5 bar. After overcoming the force of the top plug spring (16), the valve opens to equalize the pressures.

The valve is open when no pressure is applied. The pressure upstream of the valve (port B) is transmitted to the operating diaphragm (3). The positioning force produced moves the valve plug (2) depending on the spring force adjustable at the set point adjuster (10). The valve closes when the pressure upstream of the valve (port B) increases.

Type 2357-11 Pressure Reducing Valve

The process medium flows from port A to port B when the Type 2357-11 Pressure Regulator is used as a pressure reducing valve.

The valve is open when no pressure is applied. The pressure downstream of the valve (port B) is transmitted to the operating diaphragm (3). The positioning force produced moves the valve plug (2.1) depending on the spring force adjustable at the set point adjuster (10). The valve closes when the pressure downstream of the valve (port B) rises.

Type 2357-21 Excess Pressure Valve

The medium flows through the Type 2357-21 Excess Pressure Valve (Fig. 3) from port B to port A. The valve is closed when no pressure is applied. The pressure at port B is transmitted internally to the operating diaphragm (3). The positioning force produced opposes the adjustable spring force. The valve opens when the pressure increases until the set point is reached. The integrated non-return unit prevents the medium from flowing back.

EC type examination

An EC type examination according to the Pressure Equipment Directive 2014/68/EU, Module B has been performed on the Type 2357-11 Regulator.

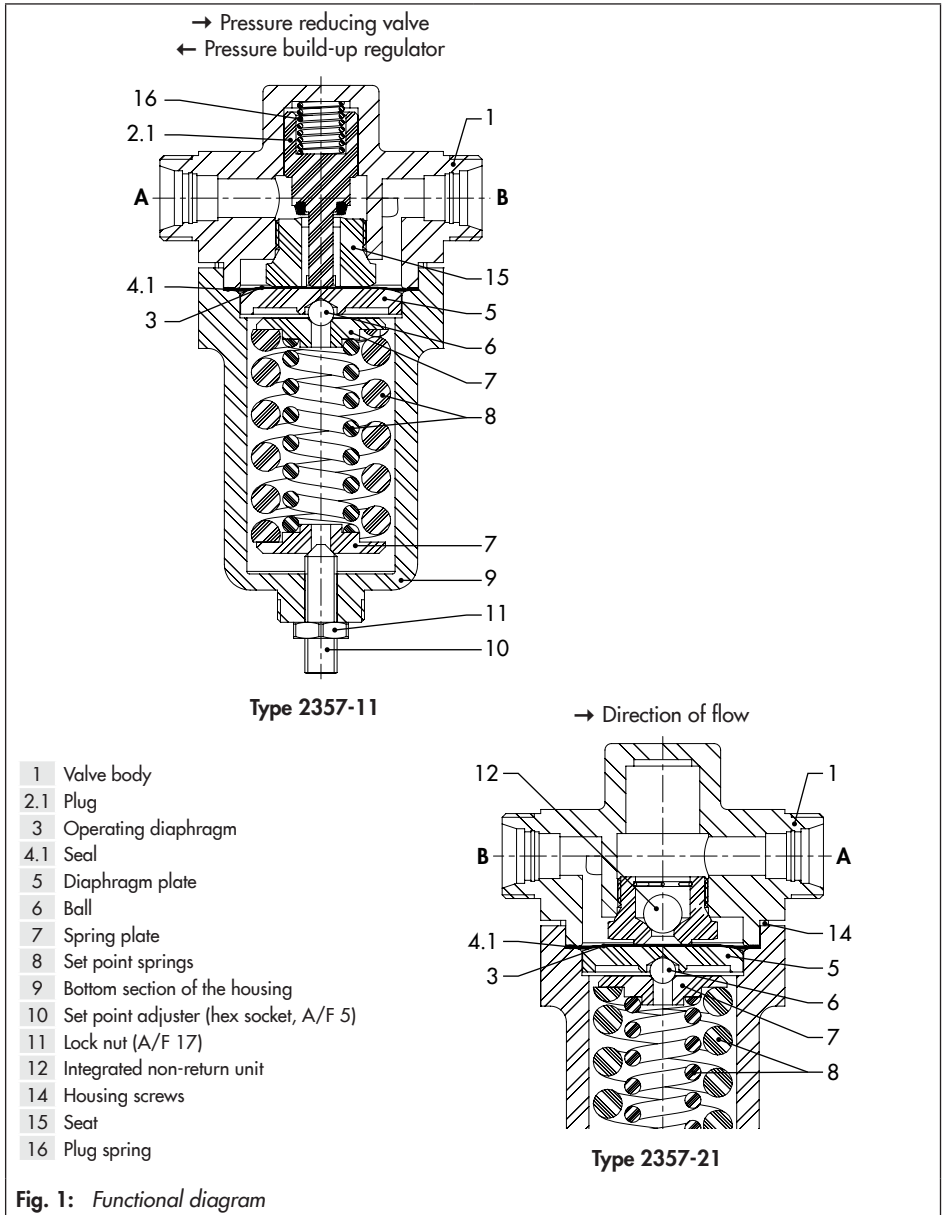

Fig. 1: Functional diagram

4 Installation

In the delivered state, the regulators are packed to be free of oil and grease for oxygen service.

⚠ WARNING

Use of oil and grease in oxygen atmospheres!

Risk of explosion!

Make sure that the regulator is absolutely clean and free of oil and grease on installing it.

Flush and clean the pipeline thoroughly before installing the regulator.

- Make sure the regulator is installed free of stress.
- Install a strainer upstream of the regulator.

Otherwise, impurities in the pipeline may impair the proper functioning of the valve, above all the tight shut-off.

4.1 Mounting orientation

Install the pressure regulator with the actuator housing suspended downward in horizontal pipelines. Observe the flow direction.

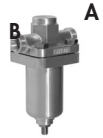

Type 2357-11 Pressure Build-up Regulator with safety function

- Direction of flow from port **B** to port **A**

Type 2357-11 Pressure Reducing Valve

- Direction of flow from port **A** to port **B**

Type 2357-21 Excess Pressure Valve with non-return unit

- Direction of flow from port **B** to port **A**.

The ports are marked.

Required spare parts and accessories are listed in Data Sheet ▶ T 2570.

4.2 Shut-off valve

We recommend installing a hand-operated shut-off valve both upstream and downstream of the regulator. This allows the plant to be shut down for cleaning and maintenance, and when the plant is not used for longer periods of time.

Install a pressure gauge at a suitable point to monitor the pressures prevailing in the plant.

5 Operation

See Fig. 1 on page 7.

5.1 Start-up

Do not start up the regulator until all parts have been mounted.

5.2 Set point adjustment

Every pressure regulator is delivered with the set point listed in Table 1 already adjusted.

Turn the set point adjuster (10) using Allen key (width across flats 5) to change the default set point.

Provided a pressure gauge has been installed at a suitable point in the plant, the required set point can be directly adjusted while monitoring the pressure reading at the gauge.

When a pressure gauge is not installed, adjust the set point using the adjustment diagram Fig. 2.

To increase the set point, turn the set point adjuster into the body (↻) and out of the body (↺) to reduce it.

! NOTICE

Set point adjuster screwed too tight!

The regulator is blocked and the medium flow through it is restricted. Pressure regulation is no longer possible.

Only screw the set point adjuster up to the point where the spring tension can still be felt.

How to proceed:

1. Undo the lock nut (11, width across flats 17) to allow the set point adjuster to move freely.
2. Determine the difference between the fixed set point (Table 1) and the required set point. Turn the set point adjuster (10) the required amount of turns as specified in Fig. 2 on page 10.

Based on the default setting, any subsequent change to the set point can also be made by determining the required number of turns using the specifications listed in Table 1.

3. Lock the setting with the lock nut (11).

5.3 Changing the set point range

The default set point ranges can be adapted to your specific requirements. Contact SAMSON (see Chapter 7) for further details.

5.4 Decommissioning

Close first the shut-off valve on the upstream side of the valve and then on the downstream side of the valve.

Servicing

Table 1: Set point adjustment (default)

Set point range		1 to 8 bar	5 to 25 bar	8 to 40 bar
Set point adjusted at the factory (approx.)	2357-11	3 bar	12 bar	25 bar
	2357-21	4 bar	13 bar	26 bar
Set point change per turn		1 bar	2.5 bar	3.5 bar

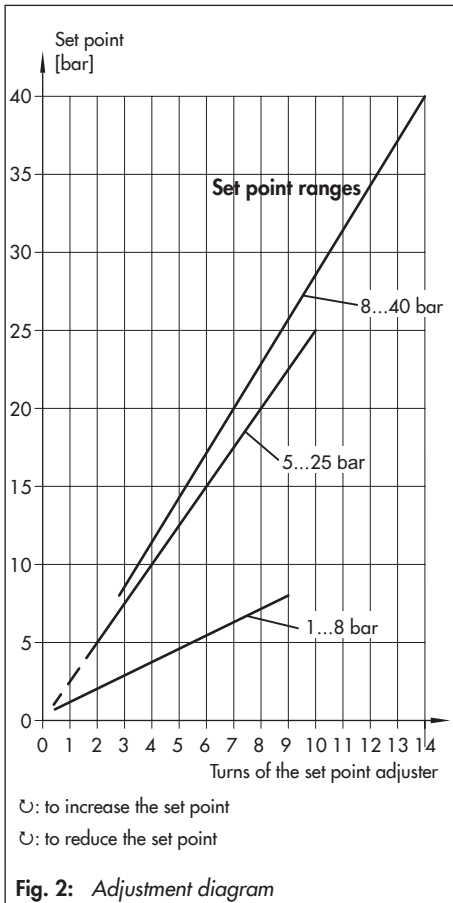

6 Servicing

The regulators do not require much maintenance. Nevertheless, they are subject to natural wear, particularly at the seat, plug and operating diaphragm.

Depending on the operating conditions, check the regulator at regular intervals to avoid possible malfunctions.

⚠ WARNING

**Process medium can escape uncontrolled on dismantling the regulator.
Risk of cold burns!**

Allow the regulator to defrost before depressurizing and draining it and remove it from the pipeline.

If faults or malfunctions cannot be remedied, contact SAMSON (see Chapter 7).

6.1 Exchanging the seat and plug

See Fig. 1.

1. Undo the lock nut (11) and turn the set point adjuster (10) counterclockwise \cup to fully relieve the internal set point springs (8).
2. Unscrew the body screws (14) using an open-end wrench (size 19 mm). Lift off the valve body (1).
3. Unscrew the seat (15) using a seat wrench (size 30 mm socket). Remove the plug (2.1).
4. Insert the plug spring (16) into the new plug (Type 2357-11 only). Tighten the seat using a seat wrench. (tightening torque of 130 Nm). Use a suitable high-performance lubricant (e.g. Gleitmo 595, SAMSON order no. 8150-0116).
5. Check the PTFE gasket (4.1) and replace it, if necessary.
6. Carefully mount the valve body (1) and fasten it onto the bottom section of the body (9) (tightening torque 50 Nm).

6.2 Exchanging the non-return unit

See Fig. 1.

1. Undo the lock nut (11) and turn the set point adjuster (10) counterclockwise \cup to fully relieve the internal set point springs (8).
2. Unscrew the body screws (14) using an open-end wrench (size 19 mm). Lift off the valve body (1).
3. Unscrew the integrated non-return unit (12) using a seat wrench (30 mm size socket) and lift off the valve body (1).
4. Check the ball and seating surface. Replace the entire non-return unit, if necessary. Mount the non-return unit using a seat wrench. (tightening torque of 130 Nm). Use a suitable high-performance lubricant (e.g. Gleitmo 595, SAMSON order no. 8150-0116).
5. Check the PTFE gasket (4.1) and replace it, if necessary.
6. Carefully mount the valve body (1) and fasten it onto the spring housing (9) using the body screws (14) (tightening torque 50 Nm).

7 After-sales service

If malfunctions or defects occur, contact the SAMSON's After-sales Service for support. The addresses of SAMSON AG, its subsidiaries, representatives and service facilities worldwide can be found on the SAMSON website (► www.samsongroup.com), in all SAMSON product catalogs or on the back of these Mounting and Operating Instructions.

Please send your inquiries to: service@samsongroup.com

To assist diagnosis and in case of an unclear mounting situation, specify the following details (see Chapter 9):

- Type designation and K_{VS} coefficient
- Model number with index
- Upstream and downstream pressure
- Temperature and process medium
- Min. and max. flow rate
- Is a strainer installed?
- Installation drawing showing the exact location of the regulator and all the additionally installed components (shut-off valves, pressure gauge etc.)

8 Disposal

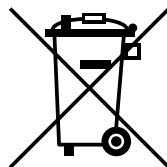

SAMSON is a producer registered at the following European institution ► <https://www.ewrn.org/national-registers/national-registers>.
WEEE reg. no.:
DE 62194439/FR 025665

- Observe local, national and international refuse regulations.
- Do not dispose of components, lubricants and hazardous substances together with your other household waste.

i Note

SAMSON can provide you with a recycling passport according to PAS 1049 on request. Simply e-mail us at aftersalesservice@samsongroup.com giving details of your company address.

💡 Tip

On request, SAMSON can appoint a service provider to dismantle and recycle the product as part of a distributor take-back scheme.

9 Nameplate

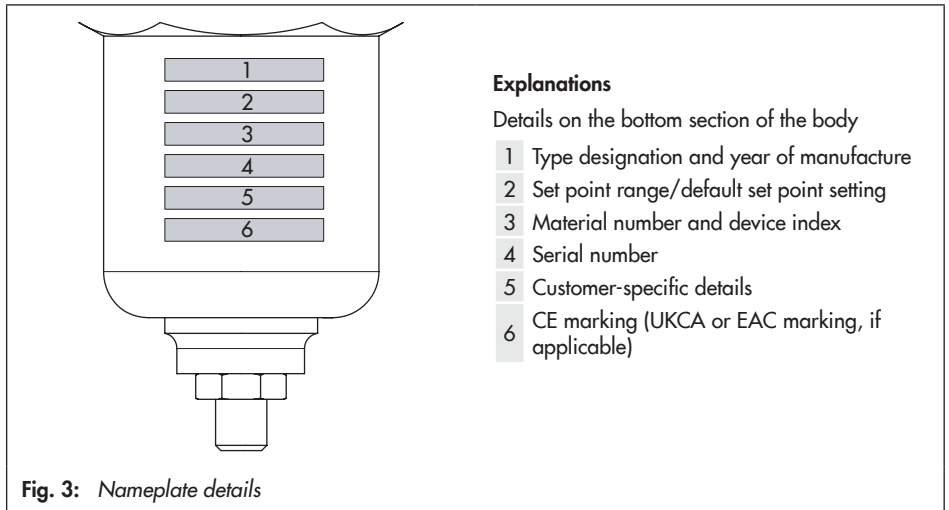

10 Dimensions and weights

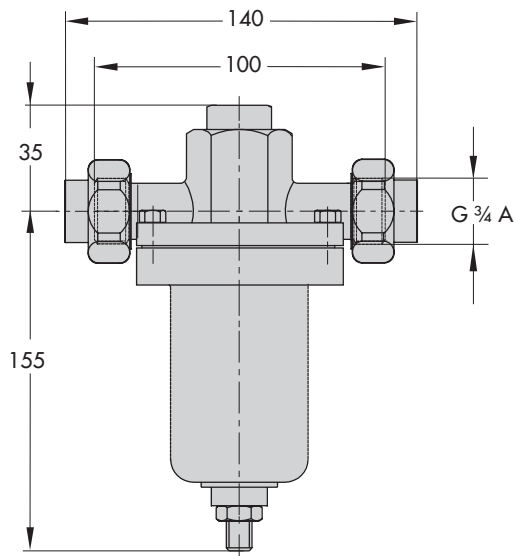

Type 2357-11 Pressure Regulator/Type 2357-21 Excess Pressure Valve with welding ends
(accessories)

Weight: approx. 4 kg

All dimensions in mm

Fig. 4: Dimensions and weights

11 Technical data

Type	2357-11	2357-21
K_{VS} coefficient	0.8	1.25
Set point ranges ¹⁾ in bar	1 to 8 · 5 to 25 · 8 to 40	
Max. permissible operating pressure p_{max}	63 bar ²⁾	
Safety function for Type 2357-11	5 bar above the set point	
Max. permissible differential pressure Δp_{max}	Types 2357-11 Pressure Reducing Valves: Gases 30 bar · Liquids 6 bar Type 2357-21 Excess Pressure Valve: 3 bar (> 3 bar only with special accessories)	
Operating time	Up to 10 years (depending on the operating conditions of the device). We recommend checking whether the device functions properly every 5 years.	
Intended lifetime	Normally 15 years (depending on the operating conditions of the device)	
Maximum storage period	24 months (provided the storage conditions specified in Chapter 2.1 are observed)	
Temperature range	-200 to +200 °C	
Conformity		

¹⁾ Further set point ranges on request

²⁾ For oxygen $p_{max} = 40$ bar

12 Certificates

The EU and UKCA declarations of conformity are included on the next pages:

- EU declaration of conformity in compliance with Pressure Equipment Directive 2014/68/EU on page 17.
- EC-type examination according to Directive 2014/68/EC, see page 18.
- EU declaration of conformity in compliance with Machinery Directive 2006/42/EC for Type 2357-11 and Type 2357-21 Regulators on page 19.
- UKCA declaration of conformity in compliance with Directive 2016 No. 1105 on page 21.
- UKCA declaration of conformity in compliance with Directive 2008 No. 1597 for Type 2357-11 and Type 2357-21 Regulators on page 22.

12.1 Information on the UK sales region

The following information corresponds to the Pressure Equipment (Safety) Regulations 2016, STATUTORY INSTRUMENTS, 2016 No. 1105 (UKCA marking). It does not apply to Northern Ireland.

Importer

SAMSON Controls Ltd
Perrywood Business Park
Honeycrock Lane
Redhill, Surrey RH1 5JQ

Phone: +44 1737 766391

E-mail: sales-uk@samsongroup.com

Website: uk.samsongroup.com

Zertifikat

EU-Baumusterprüfung (Baumuster) nach Richtlinie 2014/68/EU

Zertifikat-Nr.: 01 202 969/B-22-0002

Name und Anschrift des Herstellers: Samson AG
Weismüllerstraße 3
60315 Frankfurt

Hiermit wird bescheinigt, dass das unten genannte EU-Baumuster die Anforderungen der Richtlinie 2014/68/EU erfüllt.

Geprüft nach Richtlinie 2014/68/EU:

Modul B
EU-Baumusterprüfung (Baumuster)

Prüfbericht-Nr.: 968/FSP 2402.01/22

Beschreibung des Baumusters: Sicherheitsdruckregler ohne Hilfennergie als Ausrüstungsteil mit Sicherheitsfunktion

Typ: 2357-1, 2357-2, 2357-3, 2357-11, 2357-21

Fertigungsstätte/Lieferer: Samson AG
Weismüllerstraße 3
60315 Frankfurt

Gültig bis: 03/32
Dieses Zertifikat verliert seine Gültigkeit, wenn das Produkt in irgendeiner Weise geändert oder modifiziert wird.

Das CE-Zeichen darf erst am Produkt angebracht und die Konformitätserklärung erst ausgestellt werden, wenn ein korrespondierendes Konformitätsbewertungsverfahren der Richtlinie 2014/68/EU bezogen auf die Produktion/das Produkt vollständig erfüllt ist.

Köln, 18.03.2022



Wolf Rückwart

TÜV Rheinland Industrie Service GmbH
Notifizierte Stelle für Druckgeräte, Kennnummer 0035
Am Grauen Stein, D-51105 Köln, DEUTSCHLAND

© TÜV, TÜV und TUV sind eingetragene Marken. Eine Nutzung und Verwendung bedarf der vorherigen Zustimmung.

T1.51 MS-0001602 Rev.6
www.tuv.com

 **TÜVRheinland®**
Genau. Richtig.

EU DECLARATION OF CONFORMITY

TRANSLATION



Declaration of Conformity of Final Machinery

in accordance with Annex II, section 1.A. of the Directive 2006/42/EC

For the following products:

Type 2357-11 Pressure Build-up Regulator

We hereby declare that the machinery mentioned above complies with all applicable requirements stipulated in Machinery Directive 2006/42/EC.

For product descriptions refer to:

- Type 2357-11 Pressure Build-up Regulator: Mounting and Operating Instructions EB 2560

Referenced technical standards and/or specifications:

- VCI, VDMA, VGB: "Leitfaden Maschinenrichtlinie (2006/42/EG) – Bedeutung für Armaturen, Mai 2018" [German only]
- VCI, VDMA, VGB: "Zusatzdokument zum Leitfaden Maschinenrichtlinie (2006/42/EG) – Bedeutung für Armaturen vom Mai 2018" [German only], based on DIN EN ISO 12100:2011-03

Comment:

Information on residual risks of the machinery can be found in the mounting and operating instructions as well as in the referenced documents listed in the mounting and operating instructions.

Persons authorized to compile the technical file:

SAMSON AG, Weismüllerstraße 3, 60314 Frankfurt am Main, Germany
Frankfurt am Main, 22 August 2022

Norbert Tollas
Senior Vice President
Global Operations

Peter Scheermesser
Director
Product Maintenance and Engineered
Products

Revision no. 00

Classification: Public · SAMSON AKTIENGESELLSCHAFT · Weismüllerstraße 3 · 60314 Frankfurt am Main, Germany

Page 1 of 1

EU DECLARATION OF CONFORMITY
TRANSLATION



Declaration of Conformity of Final Machinery

in accordance with Annex II, section 1.A. of the Directive 2006/42/EC

For the following products:

Type 2357-21 Excess Pressure Valve

We hereby declare that the machinery mentioned above complies with all applicable requirements stipulated in Machinery Directive 2006/42/EC.

For product descriptions refer to:

- Type 2357-21 Excess Pressure Valve: Mounting and Operating Instructions EB 2560

Referenced technical standards and/or specifications:

- VCI, VDMA, VGB: "Leitfaden Maschinenrichtlinie (2006/42/EG) – Bedeutung für Armaturen, Mai 2018" [German only]
- VCI, VDMA, VGB: "Zusatzdokument zum Leitfaden Maschinenrichtlinie (2006/42/EG) – Bedeutung für Armaturen vom Mai 2018" [German only], based on DIN EN ISO 12100:2011-03

Comment:

Information on residual risks of the machinery can be found in the mounting and operating instructions as well as in the referenced documents listed in the mounting and operating instructions.

Persons authorized to compile the technical file:

SAMSON AG, Weismüllerstraße 3, 60314 Frankfurt am Main, Germany
Frankfurt am Main, 22 August 2022

Handwritten signature of Norbert Tollas in blue ink.

Norbert Tollas
Senior Vice President
Global Operations

Handwritten signature of Peter Scheermesser in blue ink.

Peter Scheermesser
Director
Product Maintenance and Engineered
Products

Revision no. 00

Classification: Public · SAMSON AKTIENGESELLSCHAFT · Weismüllerstraße 3 · 60314 Frankfurt am Main, Germany

Page 1 of 1



**The Pressure Equipment (Safety) Regulations 2016
Module D / N° CE-0062-PED-D-SAM 001-22-DEU**

For the following products, SAMSON hereby declares under its sole responsibility:

Devices	Type	Version
Self-operated Regulators	2357-11	Pressure Build-up Regulator
	2357-21	Excess Pressure Valve

The object of the declaration described above is in conformity with the relevant Union harmonization legislation:

Legislation: STATUTORY INSTRUMENTS – 2016 No. 1105 – CONSUMER PROTECTION HEALTH AND SAFETY – The Pressure Equipment (Safety) Regulations 2016	PE(S)R 2016	2022
EU-Type Examination	Module B	Certificate-No.: 01 202 969/B-22-0002 by TÜV Rheinland 0035
Applied conformity assessment procedure for fluids according to Article 4(1)	Module D	Certificate-No.: N°CE-0062-PED-D-SAM 001-22-DEU by Bureau Veritas 0062

The manufacturer's quality management system is monitored by the following approved body:
Bureau Veritas Services SAS, 8 Cours du Triangle, 92800 PUTEAUX – LA DEFENSE (No. 0062)
Designated Standards applied: EN 12516-3;
Other technical standards applied: ASME B16.34

Manufacturer:
SAMSON AKTIENGESELLSCHAFT, Weismüllerstraße 3, 60314 Frankfurt am Main, Germany
Frankfurt am Main, 9th November 2022

ppc. C. Tollas

Norbert Tollas
Senior Vice President
Global Operations

i. v. P. Scheermesser

Peter Scheermesser
Director
Product Maintenance & Engineered Products

Revision 00

Classification: Public · SAMSON AKTIENGESELLSCHAFT · Weismüllerstraße 3 · 60314 Frankfurt am Main, Germany

Page 1 of 1



UK DECLARATION OF CONFORMITY ORIGINAL



Declaration of Conformity of Final Machinery

in accordance with Schedule 2 Part 2 Annex II, section 1.A. of the Directive 2008 No. 1597 Supply of Machinery (Safety) Regulations 2008

For the following products:

Type 2357-11 Pressure Build-up Regulator

We hereby declare that the machinery mentioned above complies with all applicable requirements stipulated in Directive 2008 No. 1597 Supply of Machinery (Safety) Regulations 2008.

For product descriptions, refer to:

- Type 2357-11 Pressure Build-up Regulator: Mounting and Operating Instructions EB 2560

Valve accessories (e.g. positioners, limit switches, solenoid valves, lock-up valves, supply pressure regulators, volume boosters and quick exhaust valves) are classified as machinery components in this declaration of conformity. Machinery components can be mounted onto the above specified final machinery if they comply with the specifications and properties defined by SAMSON Manual H 02 "Appropriate Machinery Components for SAMSON Pneumatic Control Valves with a Declaration of Conformity of Final Machinery".

Referenced technical standards and/or specifications:

- VCI, VDMA, VGB: "Leitfaden Maschinenrichtlinie (2006/42/EG) – Bedeutung für Armaturen, Mai 2018" [German only]
- VCI, VDMA, VGB: "Zusatzdokument zum „Leitfaden Maschinenrichtlinie (2006/42/EG) – Bedeutung für Armaturen vom Mai 2018" [German only], based on DIN EN ISO 12100:2011-03

Comment:

Information on residual risks of the machinery can be found in the mounting and operating instructions of the valve and actuator as well as in the referenced documents listed in the mounting and operating instructions.

Persons authorized to compile the technical file:

SAMSON AG, Weismüllerstraße 3, 60314 Frankfurt am Main, Germany
Frankfurt am Main, 8 November 2022

i.v.

Stephan Giesen
Director
Product Management

i. v. P.

Peter Scheermesser
Director
Product Maintenance & Engineered Products

Revision 00



UK DECLARATION OF CONFORMITY ORIGINAL



Declaration of Conformity of Final Machinery

in accordance with Schedule 2 Part 2 Annex II, section 1.A. of the Directive 2008 No. 1597 Supply of Machinery (Safety) Regulations 2008

For the following products:

Type 2357-21 Excess Pressure Valve

We hereby declare that the machinery mentioned above complies with all applicable requirements stipulated in Directive 2008 No. 1597 Supply of Machinery (Safety) Regulations 2008.

For product descriptions, refer to:

- Type 2357-21 Excess Pressure Valve: Mounting and Operating Instructions EB 2560

Valve accessories (e.g. positioners, limit switches, solenoid valves, lock-up valves, supply pressure regulators, volume boosters and quick exhaust valves) are classified as machinery components in this declaration of conformity. Machinery components can be mounted onto the above specified final machinery if they comply with the specifications and properties defined by SAMSON Manual H 02 "Appropriate Machinery Components for SAMSON Pneumatic Control Valves with a Declaration of Conformity of Final Machinery".

Referenced technical standards and/or specifications:

- VCI, VDMA, VGB: "Leitfaden Maschinenrichtlinie (2006/42/EG) – Bedeutung für Armaturen, Mai 2018" [German only]
- VCI, VDMA, VGB: "Zusatzdokument zum „Leitfaden Maschinenrichtlinie (2006/42/EG) – Bedeutung für Armaturen vom Mai 2018" [German only], based on DIN EN ISO 12100:2011-03

Comment:

Information on residual risks of the machinery can be found in the mounting and operating instructions of the valve and actuator as well as in the referenced documents listed in the mounting and operating instructions.

Persons authorized to compile the technical file:

SAMSON AG, Weismüllerstraße 3, 60314 Frankfurt am Main, Germany
Frankfurt am Main, 8 November 2022

Stephan Giesen
Director
Product Management

Peter Scheermesser
Director
Product Maintenance & Engineered Products

Revision 00

EB 2560 EN



SAMSON AKTIENGESELLSCHAFT
Weismüllerstraße 3 · 60314 Frankfurt am Main, Germany
Phone: +49 69 4009-0 · Fax: +49 69 4009-1507
samson@samsongroup.com · www.samsongroup.com