

MOUNTING AND OPERATING INSTRUCTIONS



EB 3969 EN

Translation of original instructions



Type 3969 Solenoid Valve

Edition June 2018

CE Ex
certified

Note on these mounting and operating instructions

These mounting and operating instructions assist you in mounting and operating the device safely. The instructions are binding for handling SAMSON devices.

- For the safe and proper use of these instructions, read them carefully and keep them for later reference.
- If you have any questions about these instructions, contact SAMSON's After-sales Service (aftersaleservice@samsongroup.com).



The mounting and operating instructions for the devices are included in the scope of delivery. The latest documentation is available on our website at www.samsongroup.com > **Downloads** > **Documentation**.

Definition of signal words

DANGER

Hazardous situations which, if not avoided, will result in death or serious injury

WARNING

Hazardous situations which, if not avoided, could result in death or serious injury

NOTICE

Property damage message or malfunction

Note

Additional information

Tip

Recommended action

1	Safety instructions and measures	5
1.1	Notes on possible severe personal injury	8
1.2	Notes on possible personal injury	8
1.3	Notes on possible property damage	9
2	Markings on the device	10
2.1	Nameplate	10
2.2	Article code	11
2.3	Summary of explosion protection approvals	13
3	Design and principle of operation	14
3.1	Accessories and spare parts	15
3.2	Technical data	18
3.3	Dimensions in mm	22
4	Measures for preparation	27
4.1	Unpacking	27
4.2	Transporting	27
4.3	Storage	27
5	Mounting and start-up	28
5.1	Installation	28
5.1.1	Direct attachment according to VDI/VDE 3847	29
5.1.2	Rotary actuators according to VDI/VDE 3845	30
5.1.3	Attachment according to IEC 60534-6	31
5.2	Exhaust air feedback for single-acting actuators	32
5.2.1	Direct attachment according to VDI/VDE 3847	32
5.2.2	Rotary actuators according to VDI/VDE 3845	32
5.2.3	Attachment according to IEC 60534-6	32
5.3	Pneumatic connections	32
5.3.1	Connecting the supply air	32
5.3.2	Port labeling	33
5.3.3	Sizing of the connecting line	33
5.3.4	Compressed air quality	34
5.3.5	Pilot supply	34

Contents

5.4	Electrical connections	36
5.4.1	Cable entry with cable gland	36
5.4.2	Connecting the power supply	37
6	Operation	38
7	Servicing.....	38
7.1	Preparation for return shipment.....	38
8	Malfunctions	39
8.1	Troubleshooting	39
8.2	Emergency action	39
9	Decommissioning and removal	40
9.1	Decommissioning.....	40
9.2	Removing the solenoid valve.....	40
9.3	Disposal.....	40
10	Appendix.....	41
10.1	After-sales service	41

1 Safety instructions and measures

Intended use

The Type 3969 Solenoid Valve is mounted onto pneumatic linear or rotary actuators to control them. Upon failure of the air supply, the solenoid valve vents the actuator, causing the valve to move to the fail-safe position determined by the actuator. The device is designed to operate under exactly defined conditions (e.g. operating pressure, temperature). Therefore, operators must ensure that the solenoid valve is only used in applications where the operating conditions correspond to the technical data. In case operators intend to use the solenoid valve in other applications or conditions than specified, contact SAMSON.

SAMSON does not assume any liability for damage resulting from the failure to use the device for its intended purpose or for damage caused by external forces or any other external factors.

➔ Refer to the technical data for limits and fields of application as well as possible uses.

Reasonably foreseeable misuse

The solenoid valve is **not** suitable for the following applications:

- Use outside the limits defined during sizing and by the technical data

Furthermore, the following activities do not comply with the intended use:

- Use of non-original spare parts
- Performing maintenance activities not specified

Qualifications of operating personnel

The solenoid valve must be mounted, started up and serviced by fully trained and qualified personnel only; the accepted industry codes and practices are to be observed. According to these mounting and operating instructions, trained personnel refers to individuals who are able to judge the work they are assigned to and recognize possible hazards due to their specialized training, their knowledge and experience as well as their knowledge of the applicable standards.

Explosion-protected versions of this device must be operated only by personnel who has undergone special training or instructions or who is authorized to work on explosion-protected devices in hazardous areas.

Safety instructions and measures

Personal protective equipment

No personal protective equipment is required for the direct handling of the solenoid valve. Work on the control valve may be necessary when mounting or removing the device.

- Observe the requirements for personal protective equipment specified in the valve documentation.
- Check with the plant operator for details on further protective equipment.

Revisions and other modifications

Revisions, conversions or other modifications of the product are not authorized by SAMSON. They are performed at the user's own risk and may lead to safety hazards, for example. Furthermore, the product may no longer meet the requirements for its intended use.

Warning against residual hazards

The solenoid valve has a direct effect on the control valve. To avoid personal injury or property damage, plant operators and operating personnel must prevent hazards that could be caused in the control valve by the process medium, the operating pressure, the signal pressure or by moving parts by taking appropriate precautions. They must observe all hazard statements, warning and caution notes in these mounting and operating instructions, especially for installation, start-up and service work.

If inadmissible motions or forces are produced in the pneumatic actuator as a result of the supply pressure, it must be restricted using a suitable supply pressure reducing station.

Responsibilities of the operator

The operator is responsible for proper operation and compliance with the safety regulations. Operators are obliged to provide these mounting and operating instructions to the operating personnel and to instruct them in proper operation. Furthermore, the operator must ensure that operating personnel or third persons are not exposed to any danger.

Responsibilities of operating personnel

Operating personnel must read and understand these mounting and operating instructions as well as the specified hazard statements, warning and caution notes. Furthermore, the operating personnel must be familiar with the applicable health, safety and accident prevention regulations and comply with them.

Servicing explosion-protected devices

If a part of the device on which the explosion protection is based needs to be serviced, the device must not be put back into operation until a qualified inspector has assessed it according to explosion protection requirements, has issued an inspection certificate, or given the device a mark of conformity. Inspection by a qualified inspector is not required if the manufacturer performs a routine test on the device before putting it back into operation. Document the passing of the routine test by attaching a mark of conformity to the device. Replace explosion-protected components only with original, routine-tested components by the manufacturer.

Devices that have already been operated outside hazardous areas and are intended for future use inside hazardous areas must comply with the safety requirements placed on serviced devices. Before being operated inside hazardous areas, test the devices according to the specifications for servicing explosion-protected devices.

Maintenance, calibration and work on equipment

- ➔ Only use intrinsically safe current/voltage calibrators and measuring instruments for interconnection with intrinsically safe circuits to check or calibrate the equipment inside or outside hazardous areas.
- ➔ Observe the maximum permissible values specified in the appendix of this document for the intrinsically safe circuit.

Referenced standards and regulations

Devices with a CE marking fulfill the requirements of the Directives 2014/30/EU and 2014/34/EU. This EU declaration of conformity is included in the appendix of this document.

Referenced documentation

The following documents apply in addition to these mounting and operating instructions:

- The mounting and operating instructions of the components on which the solenoid valve is mounted (valve, actuator, valve accessories etc.)
- Safety manual of the solenoid valve ► SH 3969
- Safety manual of the restrictor plates ► SH 3967-2

1.1 Notes on possible severe personal injury

DANGER

Risk of fatal injury due to the formation of an explosive atmosphere.

Incorrect installation, operation or maintenance of the solenoid valve in potentially explosive atmospheres may lead to ignition of the atmosphere and cause death.

- For mounting and electrical installation in hazardous areas, observe the explosion protection approvals as well as the relevant electrotechnical regulations and the accident prevention regulations that apply in the country of use.
- EN 60079-14 applies in Europe: Electrical installations design, selection and erection
- Observe the type of protection and the specific conditions for the type of protection according to the instructions for explosion protection in the appendix of this document.

Risk of fatal injury as a result of electrostatic discharge at the device.

- In hazardous areas (with type of protection Ex t), mount the device in such a way that electrostatic charging cannot take place.

1.2 Notes on possible personal injury

WARNING

Incorrect electrical connection will render the explosion protection unsafe.

- Adhere to the terminal assignment and observe correct polarity.
- Do not undo the enameled screws.
- Do not exceed the maximum permissible values (U_i , I_i , P_i , C_i , L_i) specified in the EC type examination certificates when interconnecting intrinsically safe electrical equipment.

Risk of personal injury due to moving parts on the valve.

During operation and when the solenoid valve is triggered, the actuator stem moves through its entire travel range. Injury to hands or fingers is possible if they are inserted into the valve.

- While the valve moves, do not insert hands or fingers into the valve yoke and do not touch any moving valve parts.

1.3 Notes on possible property damage

! NOTICE

Risk of damage to the solenoid valve due to incorrect mounting position.

→ Do not seal the vent opening when the device is installed on site.

Risk of damage to the solenoid valve due to impermissible pressures.

→ Do not connect a supply pressure to the solenoid valve that exceeds the maximum supply pressure.

Incorrect assignment of the terminals will damage the solenoid valve and will lead to malfunction.

For the solenoid valve to function properly, the prescribed terminal assignment must be observed.

→ Connect the electrical wiring to the solenoid valve according to the prescribed terminal assignment.

2 Markings on the device

2.1 Nameplate

Version without explosion protection

SAMSON 3969		CE	
Solenoid valve $U_n = 14$ to 24 V DC			
⚠ See technical data for ambient temperature			
Model 3969 - 000		1	
Var.-ID	2		
Serial no.	3	5	6
Order no.	4		
SAMSON AG, Germany		Made in Germany	

Version with explosion protection

SAMSON 3969		CE	
Solenoid valve $U_n = 14$ to 24 V DC		0044	
	II 2 G Ex ia IIC T4 Gb*		
	TÜV 17 ATEX 8047 X		
* $U_i \leq 28$ V ; * $I_i \leq 115$ mA ; * $P_i \leq 1$ W			
⚠ * See technical data and explosion-protection certificate for permissible ambient temperature and maximum values for connection to certified intrinsically safe circuits. -45 °C $\leq T_a^* \leq +80$ °C			
Model 3969 - 110		1	
Var.-ID	2		
Serial no.	3		
Order no.	4	5	6
SAMSON AG, D 60314 Frankfurt		Made in Germany	

- 1 Article code
- 2 Configuration ID
- 3 Serial number
- 4 Order number
- 5 Device index
- 6 Safety approval

Markings on the device



Solenoid valve	Type 3969-	x	x	x	x	x	x	x	x	x	x	x	x	x	x	x	x	x	x	x
$K_{VS}^{1)}$																				
0.3	0																			
2.0	2																			
4.3	4																			
Material																				
Aluminum	1																			
Pneumatic connection																				
G ¼	1																			
¼ NPT	2																			
G ½	3																			
½ NPT	4																			
Pilot valve connection																				
Without (ports sealed by two blanking plugs)	0																			
1 (with internal pilot supply)	1																			
2 (with external pilot supply)	2																			
Pilot supply																				
Internal pilot supply for actuators for on/off service	1																			
External pilot supply for actuators for throttling service	2																			
Electrical connection																				
Without cable gland	0	0																		
Cable gland M20x1.5 made of black polyamide	0	1																		
Cable gland M20x1.5 made of blue polyamide	1	1																		
Cable gland M20x1.5 made of black polyamide (Ex e, CEAG)	1	3																		
Cable gland M20x1.5 made of blue polyamide (Ex e, CEAG)	1	4																		
Cable gland M20x1.5, nickel-plated brass	1	5																		
Cable gland M20x1.5, brass, blue	1	6																		
Degree of protection																				
IP 65																				0

1) The maximum permissible ambient temperature depends on the permissible ambient temperature of the components, type of protection and temperature class.

2) SIL according to IEC 61508

Solenoid valve	Type 3969-	x	x	x	x	x	x	x	x	x	x	x	x	x	x	x	x	x	x	x
Ambient temperature ¹⁾																				
-20 to +80 °C		0																		
-45 to +80 °C		1																		
Safety function																				
Without		0																		
SIL ²⁾		1																		
Restrictor plate																				
Without			0	0	0															
With exhaust air restrictor plate			1	0	0															
With supply air restrictor plate			2	0	0															
With exhaust air and supply air restrictor plates			3	0	0															

2.3 Summary of explosion protection approvals

Type	Certification		Type of protection/comments
3969	SIL	Number 968/V 1034.0017	Certification for safety-instrumented systems according to IEC 61508
		Date 2017-04-12	
3969-1	 EU type examination certificate	Number TÜV 17 ATEX 8047 X	II 2G Ex ia IIC T4/T6 Gb II 2D Ex ia IIIC T85°C Db
		Date 2019-03-12	
	IECEX	Number IECEx TUR 17.0027X	Ex ia IIC T4/T6 Gb Ex ia IIIC T85°C Db
		Date 2019-03-12	
3969-8	 EU type examination certificate	Number TÜV 17 ATEX 8048 X	II 3G Ex ec IIC T4/T6 Gc II 3G Ex nA IIC T4/T6 Gc II 2D Ex tb IIIC T85°C Db
		Date 2019-03-12	
	IECEX	Number IECEx TUR 17.0027X	Ex ec (or nA) IIC T4/T6 Gc Ex tb IIIC T85°C Db
		Date 2019-03-12	

3 Design and principle of operation

The solenoid valve consists of an electro-pneumatic binary converter with manual override and integrated poppet valve actuated on one side with return spring.

The pilot supply for the electropneumatic binary converter is fed internally through port 1 or externally through port 9. By turning the turnable gasket, the pilot supply can be changed.

In the idle position, the armature is pressed against the seat of the supply air port by the spring. This causes the ball to close the hole for the pilot supply port and prevents the solenoid valve from consuming air.

The solenoid coil is energized by an electric binary signal which causes the armature to be lifted out of the seat of the supply air port against the force of the spring and drawn into the exhaust air port. This causes the pressure to rise above the activation pressure of the integrated poppet valve and switches it to the operating position. After the solenoid coil is de-energized, the integrated poppet valve is switched to the idle position again by a return spring.

Optionally, the solenoid valve can be upgraded to become a pneumatic poppet valve actuated on one side. This results in higher K_{VS} coefficients (see Data Sheet ► T 3756).

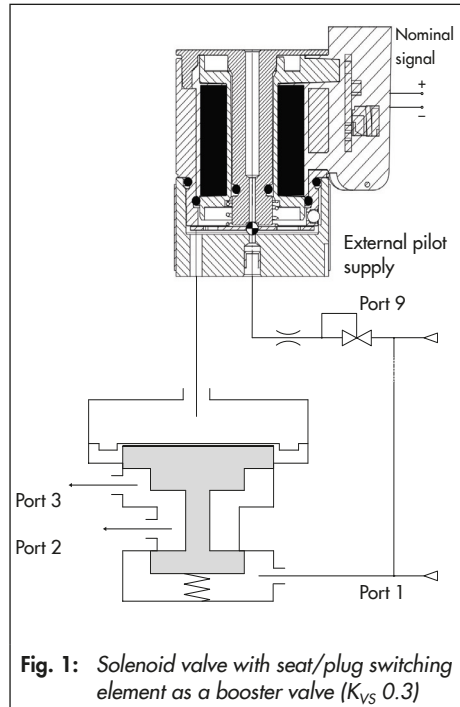

3.1 Accessories and spare parts

General

Designation	Order no.
Enclosure cover	1380-2978
Gasket (for enclosure cover)	0430-3601
Blanking plug G ¼, stainless steel 1.4571 (for threaded connections)	0070-0858
Blanking plug ¼ NPT, stainless steel 1.4571 (for threaded connections)	0070-0862
O-ring 14x1.5 made of nitrile butadiene rubber (for blanking plug)	8421-0070
Turnable gasket (for connecting plate)	0430-3595
Fastening screw (for connecting plate) A4-90, 45x20 (1 pc.)	0180-1523
Fastening screw (for connecting plate) A4-90, 45x35 (2 pcs.)	0180-1524
Filter ¼ (for connecting plate)	0550-0213
Molded seal (for NAMUR interface ¼, K _{VS} 0.3)	0430-1883
O-ring 16x2, -20 to +80 °C (for poppet valves with NAMUR interface ¼, K _{VS} 2.0)	8421-0364
O-ring 16x2, -45 to +80 °C (for booster valves with NAMUR interface ¼, K _{VS} 2.0)	8421-0368
O-ring 24x2, -20 to +80 °C (for poppet valves with NAMUR interface ½, K _{VS} 4.3)	8421-1077
O-ring 24x2, -45 to +80 °C (for poppet valves with NAMUR interface ½, K _{VS} 4.3)	8421-0425
Screw M5x60 A4 (for poppet valves with NAMUR interface, K _{VS} 2.0)	8333-1303
Spring washer A5-A4 (for poppet valves with NAMUR interface, K _{VS} 2.0)	8392-0651
Screw M5x60 A4 (for poppet valves with NAMUR interface, K _{VS} 4.3)	8333-0538
Spring washer A5-A4 (for booster valves with NAMUR interface, K _{VS} 4.3)	8392-0658
Cable gland M20x1.5 made of black polyamide, 6 to 12 mm cable diameter	8808-1011
Cable gland M20x1.5 made of blue polyamide, 6 to 12 mm cable diameter	8808-1012
NBR O-ring 18x2 (for cable gland)	8421-0067
Cable gland M20x1.5 made of black polyamide, 5 to 13 mm cable diameter (Ex e, CEAG)	8808-0178
Cable gland M20x1.5 made of blue polyamide, 5 to 13 mm cable diameter	8808-0179
Cable gland M20x1.5, nickel-plated brass, 6 to 12 mm cable diameter	8808-0138
Cable gland M20x1.5, brass, blue, 6 to 12 mm cable diameter	1890-4876
Cable gland M20x1.5, nickel-plated brass, 7 to 12 mm cable diameter (Ex e, CEAG)	8808-2043
Cable gland M20x1.5 made of blue polyamide, 10 to 14 mm cable diameter	8808-2016
Blanking plug M20x1.5, black polyamide (for cable entry)	8808-1025
NBR O-ring 18x2 (for blanking plug)	8421-0067

Design and principle of operation

Designation	Order no.
Blanking plug M20x1.5, nickel-plated brass (Ex e, CEAG) (for cable entry)	8808-3513
Screw plug G ¼ (for pneumatic connection)	0070-0858
Screw plug ¼ NPT (for pneumatic connection)	0070-0862
NBR O-ring 14x1.5 (for screw plug)	8421-0067

Accessories for K_{VS} 0.3

Designation	Order no.
Mounting block for SAMSON Type 3277 Pneumatic Actuator	
G ¼ connection	1400-8817
¼ NPT connection	1400-8818
Pressure gauge mounting block, 1x Output and 1x Supply, made of stainless steel/brass (for mounting block)	1400-6950
Piping for actuator with "stem retracts" fail-safe action	
240 cm ² actuator area, zinc-plated steel	1400-6444
240 cm ² actuator area, CrNiMo steel	1400-6445
350 cm ² actuator area, zinc-plated steel	1400-6446
350 cm ² actuator area, CrNiMo steel	1400-6447
700 cm ² actuator area, zinc-plated steel	1400-6448
700 cm ² actuator area, CrNiMo steel	1400-6449

Accessories for K_{VS} 2.0

Designation	Order no.
Adapter plate for NAMUR rib acc. to IEC 60534-6-1	
Aluminum, powder coated, gray beige RAL 1019, G ¼ connection	1400-6751
Aluminum, powder coated, gray beige RAL 1019, ¼ NPT connection	1400-9924
Adapter plate for NAMUR interface ¼ on NAMUR rib ½	
Aluminum, powder coated, gray beige RAL 1019	1380-1652
Stainless steel 1.4404	1380-1797

Accessories for K_{V5} 4.3

Designation	Order no.
Adapter plate for NAMUR interface ½ to thread ½	
Aluminum, powder coated, gray beige RAL 1019, G ½ connection	0360-3945
Aluminum, powder coated, gray beige RAL 1019, ½ NPT connection	0360-3946
Stainless steel 1.4404, G ½ connection	0360-3947
Stainless steel 1.4404, ½ NPT connection	0360-3948
Adapter plate for NAMUR interface ½ on NAMUR rib ½	
Aluminum, powder coated, gray beige RAL 1019	1380-1795
Stainless steel 1.4404	1380-1796
Adapter plate for NAMUR rib acc. to IEC 60534-6-1	
Aluminum, powder coated, gray beige RAL 1019, G ½ connection	1402-0827
Aluminum, powder coated, gray beige RAL 1019, ½ NPT connection	1402-0829
Stainless steel 1.4404, G ½ connection	1402-0828
Stainless steel 1.4404, ½ NPT connection	1402-0830
Double-axial adapter	
90°, aluminum, powder coated, gray beige RAL 1019	1402-0602
90°, stainless steel 1.4404	1402-0603

3.2 Technical data

General data		
Design		Solenoid with armature and ball/seat valve with return spring
Degree of protection		IP 65 with filter check valve
Compliance		CE · RoHS
Materials	Enclosure	Black anodized aluminum (C35)
	Connecting plate	Black anodized aluminum (C35)
	Adapter plate	Aluminum, powder coated, gray beige RAL 1019
	Screws	Stainless steel A4-70
	Springs	Stainless steel 1.4310
	Seals	Silicone rubber
Environmental conditions according to EN 60721-3	Storage	1K5 (relative humidity $\leq 95\%$)
	Transport	2K4
	Operation	4K3 -45 to +80 °C
Ambient temperature ¹⁾		-45 to +80 °C
Mounting position		Any desired position
Resistance to vibration		According to EN 60068-2-27 According to EN 60068-2-47 Recommended continuous duty $\leq 150 \text{ m/s}^2$

¹⁾ The maximum permissible ambient temperature depends on the permissible ambient temperature of the components, type of protection and temperature class.

Electric data		
Nominal signal	U_N	14 to 24 V DC ²⁾
Switching point	ON	$U_{80\text{ °C}}$
		I
		$P_{20\text{ °C}}$
	OFF	I
Input impedance	$R_{20\text{ °C}}$	1.87 k Ω
Temperature influence		0.39 %/°C
Type of protection ³⁾		Intrinsic safety: II 2G Ex ia IIC T4/T6 Gb II 2D Ex ia IIIC T85 °C Db Non-sparking: II 3 G Ex ec IIC T4/T6 Gc or II 3 G nA IIC T4/T6 Gc II 2 D Ex tb IIIC T85°C Db
Output voltage ⁴⁾	U_i (V)	28
Output current ⁴⁾	I_i (mA)	115
Power dissipation ⁴⁾	P_i (W)	1
Outer capacitance ⁴⁾	C_i (nF)	Negligibly small
Outer inductance ⁴⁾	L_i (mH)	Negligibly small
Ambient temperature ¹⁾		-45 to +80 °C (temperature class T4)
Electrical connection		Screw terminal, 2-pole, with cable gland M20x1.5
Grounding terminal		External ($A_{\text{max}} = 4 \text{ mm}^2$)

- 1) The maximum permissible ambient temperature depends on the permissible ambient temperature of the components, type of protection and temperature class.
- 2) Maximum permissible value at 100 % duty cycle. The maximum permissible value U_i applies to explosion-protected versions.
- 3) According to EU type examination certificate and statement of conformity
- 4) Permissible maximum values when connected to a certified intrinsically safe circuit.

Design and principle of operation

Pneumatic data for solenoid valve with K_{VS} 0.3, actuated on one side	
Switching function	3/2-way function with exhaust air feedback
K_{VS} ¹⁾	0.3
Safety approval	SIL ²⁾
Compressed air quality according to ISO 8573-1	Max. particle size and density: Class 4
	Oil content: Class 3
	Pressure dew point: Class 3 or at least 10 K below the lowest ambient temperature to be expected
Pilot supply Medium Pressure ³⁾	Instrument air (free from corrosive substances) oil or non-corrosive gases
	1.4 to 10 bar
Operating medium	Instrument air, free from corrosive substances
Operating pressure	Max. 10 bar
Switching time	≤60 ms
Connection	G 1/4, 1/4 NPT or NAMUR interface 1/4 ⁴⁾
Weight	0.7 kg
	1.05 kg (with adapter plate)

1) The air flow rate when $p_1 = 2.4$ bar and $p_2 = 1.0$ bar is calculated using the following formula:

$$Q = K_{VS} \times 36.22 \text{ in m}^3/\text{h.}$$

2) SIL according to IEC 61508

3) When using the solenoid valve with an operating pressure of 10 bar, a minimum pilot pressure of 1.9 bar is required.

4) NAMUR interface according to VDI/VDE 3845 and VDI/VDE 3847

Poppet valve with NAMUR interface, K_{VS} 2.0 or 4.3, actuated on one side			
Switching function		3/2-way function	
K_{VS} ¹⁾ (direction of flow)		1.1 (4×3)	1.9 (4×3)
		2.0 (3×5)	4.3 (3×5)
Safety approval		SIL ²⁾	
Design		Poppet valve with diaphragm actuator, soft seated, with return spring	
Material	Enclosure	Aluminum, powder coated, gray beige RAL 1019 or Stainless steel 1.4404	
	Diaphragms	Chloroprene rubber (-20 to +80 °C) or silicone rubber (-45 to +80 °C)	
	Seals	Chloroprene rubber (-20 to +80 °C) or silicone rubber (-45 to +80 °C)	
	Screws	Stainless steel 1.4571	
	Springs	Stainless steel 1.4310	
Operating medium		Instrument air free from corrosive substances or nitrogen ³⁾ Air containing oil or non-corrosive gases ⁴⁾	
Compressed air quality according to ISO 8573-1		Max. particle size and density: Class 4 Oil content: Class 3 Pressure dew point: Class 3 or at least 10 K below the lowest ambient temperature to be expected	
Actuation		With VDI/VDE 3847 interface	
Pilot supply		2.7 to 6 bar ³⁾	
		1.4 to 6 bar ⁴⁾	
Max. operating pressure		10.0 bar	
Ambient temperature ⁵⁾		-20 to +80 °C -45 to +80 °C	
Connection	Supply air	G ¼ or ¼ NPT	G ¼ or ¼ NPT
	Exhaust air	G ½ or ½ NPT and NAMUR interface ¼ ⁶⁾ with G (NPT) ⅜	G ½ or ½ NPT and NAMUR interface ½ ⁶⁾
Approx. weight		1.38 kg	1.5 kg

¹⁾ The air flow rate when $p_1 = 2.4$ bar and $p_2 = 1.0$ bar is calculated using the following formula:

$$Q = K_{VS} \times 36.22 \text{ in m}^3/\text{h.}$$

²⁾ SIL according to IEC 61508

³⁾ With internal pilot supply

⁴⁾ With external pilot supply

⁵⁾ The maximum permissible ambient temperature depends on the permissible ambient temperature of the components, type of protection and temperature class.

⁶⁾ NAMUR interface according to VDI/VDE 3845

3.3 Dimensions in mm

Version with NAMUR interface 1/4" according to VDI/VDE 3845 and direct attachment according to VDI/VDE 3847

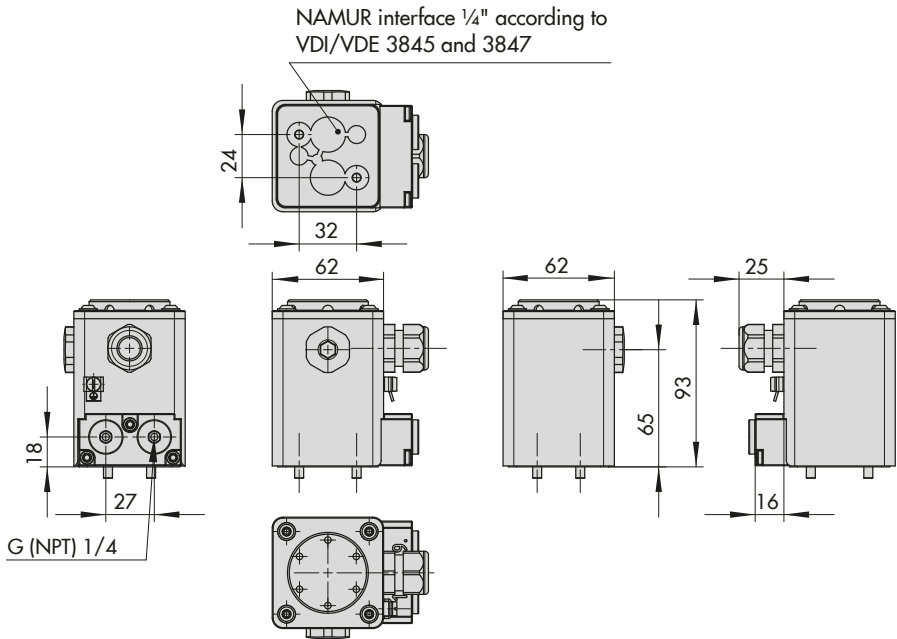

Version with NAMUR interface 1/4" according to VDI/VDE 3845 and direct attachment according to VDI/VDE 3847 and restrictor plate

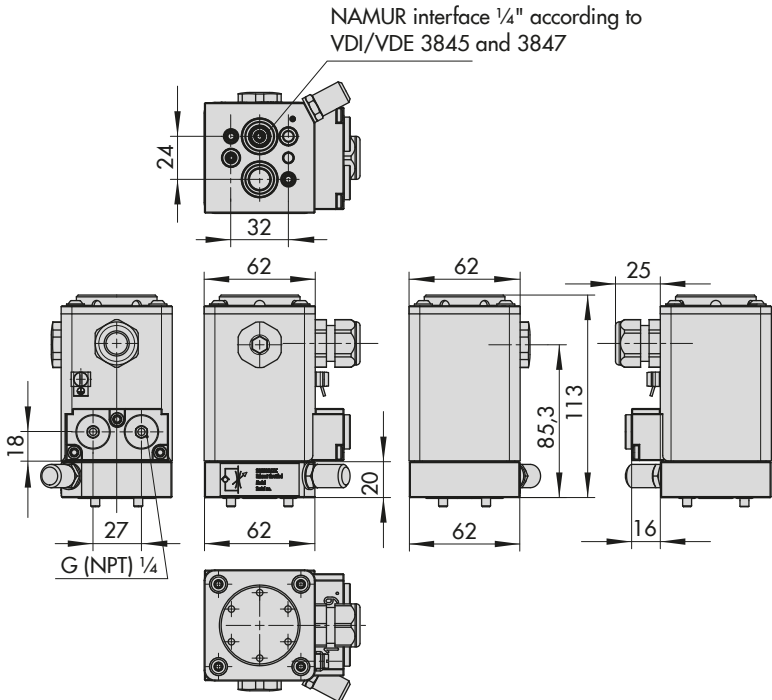

Design and principle of operation

Version with adapter plate for linear actuators with NAMUR rib according to IEC 60531-6-1

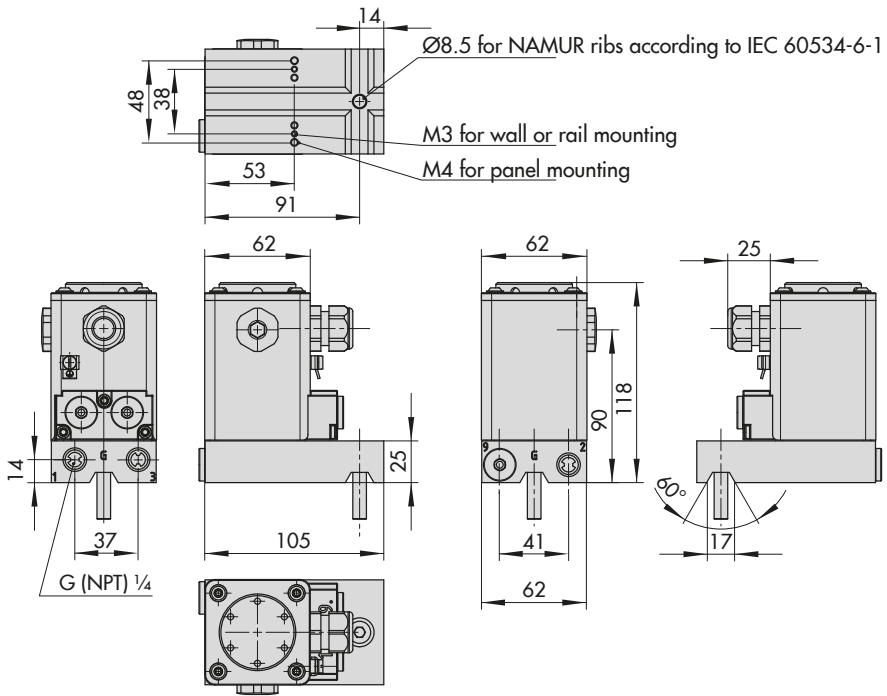

Version with booster valve ($K_{VS} 2.0$)

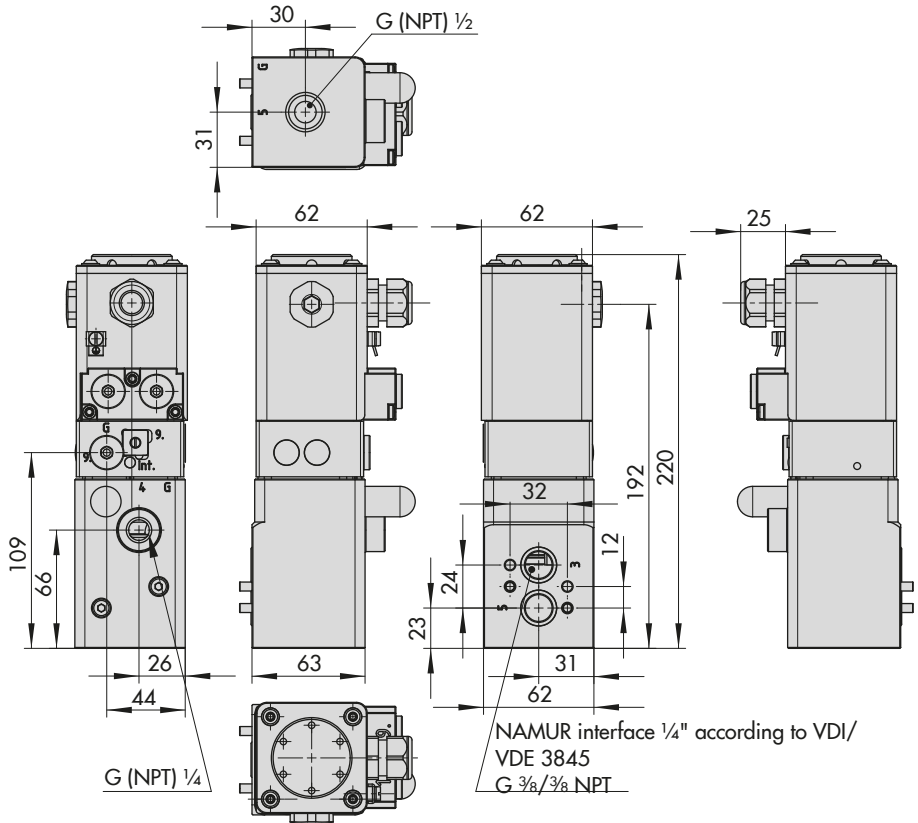

Design and principle of operation

Version with poppet valve (K_{VS} 4.3)

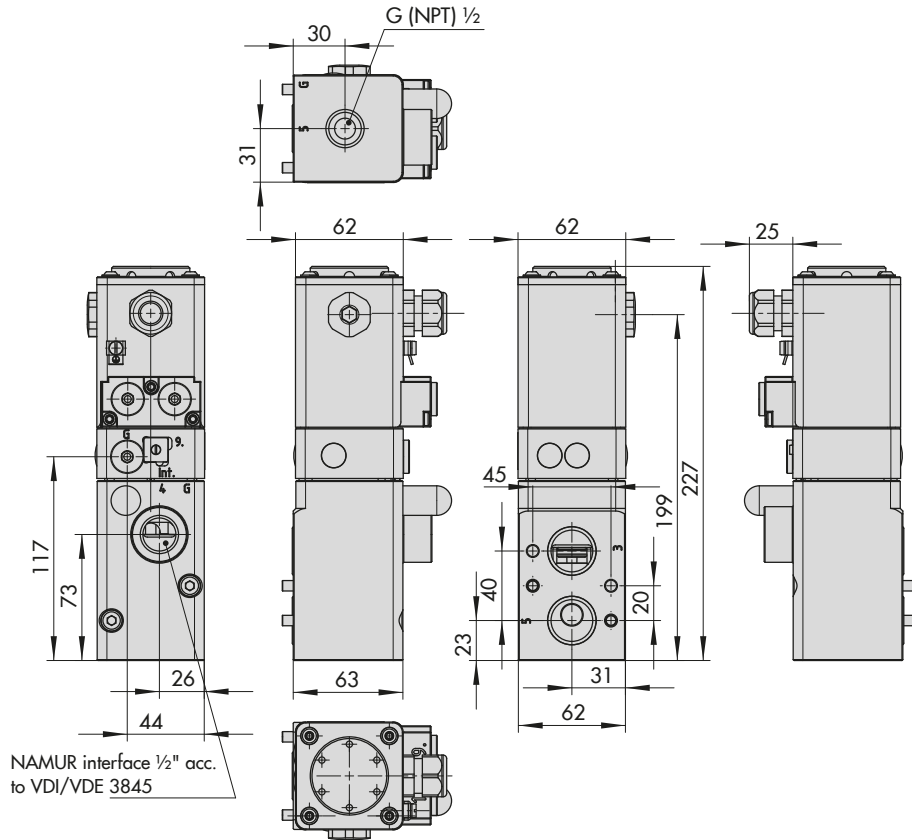

4 Measures for preparation

After receiving the shipment, proceed as follows:

1. Check the scope of delivery. Compare the shipment received with the delivery note.
2. Check the shipment for transportation damage. Report any transportation damage.

4.1 Unpacking

! NOTICE

Risk of solenoid valve damage due to foreign particles entering the valve. Do not remove the packaging and protective film/protective caps until immediately before mounting and start-up.

1. Remove the packaging from the solenoid valve.
2. Dispose of the packaging in accordance with the valid regulations.

4.2 Transporting

- Protect the solenoid valve against external influences (e.g. impact).
- Protect the solenoid valve against moisture and dirt.
- Observe transport temperature depending on the permissible ambient temperature (see technical data in section 3.2).

4.3 Storage

! NOTICE

Risk of solenoid valve damage due to improper storage.

- Observe the storage instructions.
- Avoid long storage times.
- Contact SAMSON in case of different storage conditions or long storage periods.

Storage instructions

- Protect the solenoid valve against external influences (e.g. impact, shocks, vibration).
- Do not damage the corrosion protection (coating).
- Protect the solenoid valve against moisture and dirt. In damp spaces, prevent condensation. If necessary, use a drying agent or heating.
- Observe storage temperature depending on the permissible ambient temperature (see technical data in section 3.2).
- Store solenoid valve with the cover closed.
- Seal the pneumatic and electrical connections.

5 Mounting and start-up

! NOTICE

Risk of malfunction due to incorrect sequence of mounting, installation and start-up. Observe the prescribed sequence.

→ Sequence:

1. Remove the protective caps from the pneumatic connections.

→ Section 5.1 onwards

3. Perform pneumatic installation.

→ Section 5.3 onwards

4. Perform electrical installation.

→ Section 5.4 onwards

5.1 Installation

Any mounting position may be used. The following applies concerning the installation:

- Install the solenoid valve in such a way that the M20x1.5 cable gland faces downward (in cases where this is not possible, mount it in the horizontal position).
- On mounting, make sure that 200 mm or more clearance is kept above the enclosure cover.

5.1.1 Direct attachment according to VDI/VDE 3847

For Type 3277 Actuators with 175 to 750 cm² or solenoid valve interfaces according to VDI/VDE 3847. Required mounting parts and accessories: see section 3.1.

1. Seal ports 1 and 9 at the device with stainless steel blanking plugs.
2. Remove the connecting plate and turn the turnable gasket so that its tag points to port 9. Remount the connecting plate.

If the solenoid valve is configured for direct attachment to the mounting block with positioner according to VDI/VDE 3847, steps 1 and 2 are not required.

3. Check the location of the formed seal and the code screw on the NAMUR interface.

4. Use two cap screws to fasten the solenoid valve onto the mounting block.

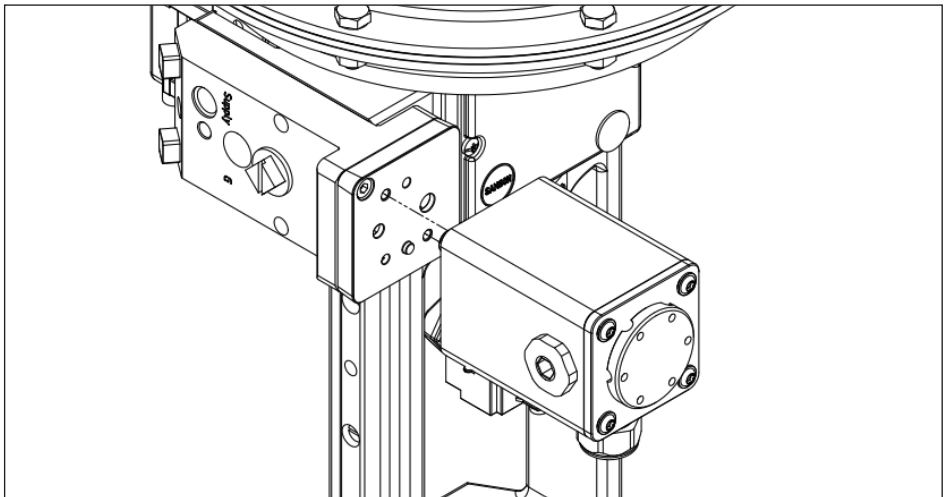
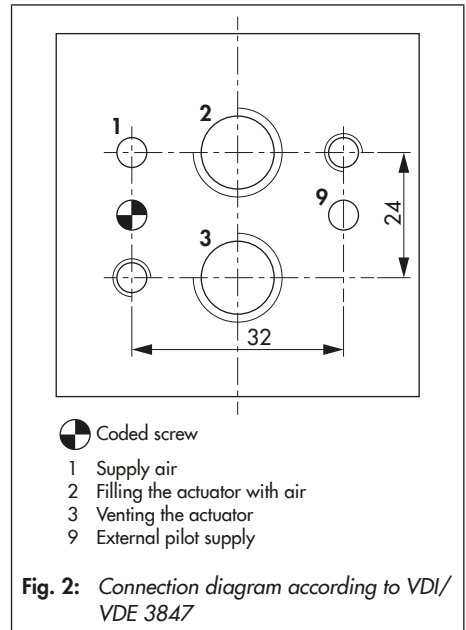

5.1.2 Rotary actuators according to VDI/VDE 3845

Required mounting parts and accessories: see section 3.1.

If the solenoid valve is configured for attachment to rotary actuators according to VDI/VDE 3845, no additional mounting parts are required.

1. Check the location of the formed seal or O-rings on the NAMUR interface and that of the coded screw.
2. Use two cap screws to fasten the solenoid valve on to the rotary actuator.

The solenoid valve can be configured with an external connecting plate to facilitate servicing work, device replacement or interconnection with other devices for exhaust air feedback (see section 5.2.2).

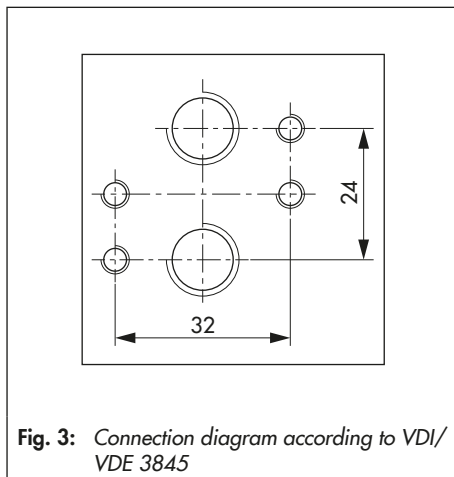
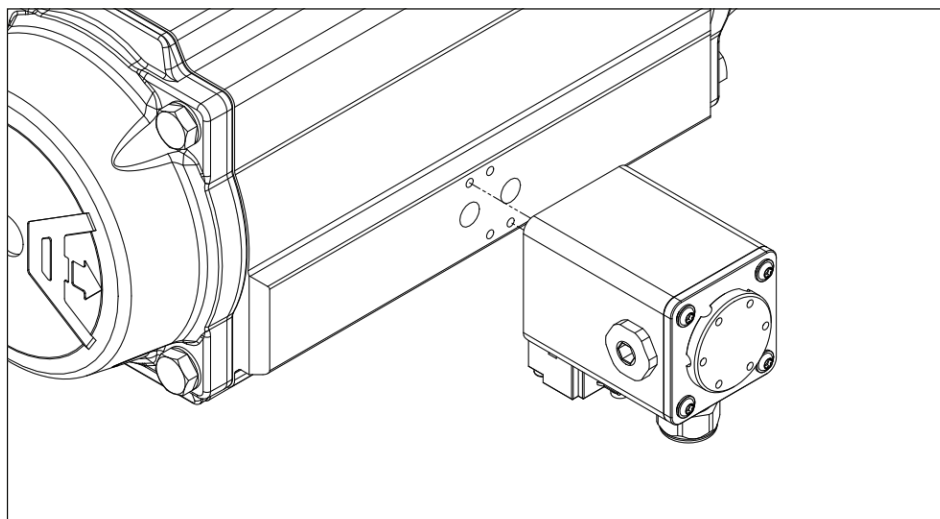

Fig. 3: Connection diagram according to VDI/VDE 3845



5.1.3 Attachment according to IEC 60534-6

Required mounting parts and accessories: see section 3.1.

If the solenoid valve is not configured for attachment according to IEC 60534-6 (NAMUR rib), additional mounting parts are only required for mounting onto valves with rod-type yokes.

1. Check the location of the formed seal or O-rings on the NAMUR interface and that of the coded screw.
2. Use two cap screws to fasten the solenoid valve on to the adapter plate of the NAMUR rib.

If the solenoid valve is configured for attachment according to IEC 60534-6 (NAMUR rib), steps 1 and 2 are not required.

3. For valves with rod-type yokes only: Fasten the support and the rod clamping plate loosely to the rod.
4. Use a cap screw to fasten the solenoid valve to the yoke/support.

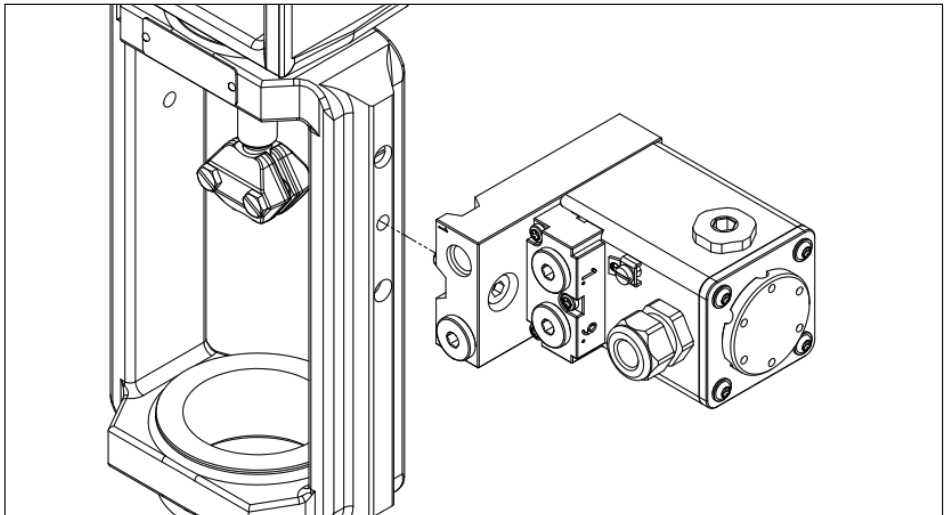

5.2 Exhaust air feedback for single-acting actuators

The instrument air leaving the solenoid valve is diverted to the actuator spring chamber to provide corrosion protection inside the actuator.

5.2.1 Direct attachment according to VDI/VDE 3847

Direction of action: actuator stem extends

Remove the blanking plug in the vent connection at the connection block and make a pneumatic connection to the spring chamber on the vented side.



Tip

The corresponding pipe fittings to establish the air connections are listed in section 3.1.

Direction of action: actuator stem retracts

The exhaust air feedback is automatically provided.

5.2.2 Rotary actuators according to VDI/VDE 3845

The exhaust air feedback is automatically provided. Should other valve accessories be used which vent the actuator (e.g. positioner etc.), the exhaust air of this device can also be included in the exhaust air feedback over port 3 of the adapter plate as part of the configuration of the external connecting

plate (see section 3.1). A separate venting is not required since the air is vented through the solenoid valve cover.

5.2.3 Attachment according to IEC 60534-6

1. Mount the solenoid valve as described in section 5.1.3.
2. Connect port 3 to the actuator's spring chamber.

Should other valve accessories be used which vent the actuator (e.g. positioner etc.), the exhaust air of this device can also be included in the pipe hook-up. A separate venting is not required since the air is vented through the solenoid valve cover.

5.3 Pneumatic connections

⚠ WARNING

Risk of injury by possible movement of exposed parts (actuator or valve) after connecting the pilot supply.

Do not touch or block exposed moving parts.

5.3.1 Connecting the supply air

ⓘ NOTICE

Risk of malfunction due to incorrect sequence of mounting, installation and start-up.

Observe the following sequence.

1. Remove the protective caps from the pneumatic connections.

2. Mount the solenoid valve to the control valve.
3. Connect the supply air.
4. Connect the power supply.

The pneumatic connections are optionally designed as a bore with 1/4 NPT or G 1/4 thread. Customary fittings for metal or copper tubing or plastic hoses can be used.

- ➔ Run and attach the connecting lines and screw joints according to good professional practice.
- ➔ Check the connecting lines and screw joints for leaks and damage at regular intervals and repair them.
- ➔ The K_{VS} coefficient of an upstream pressure reducing valve must be at least 1.6 times larger than the K_{VS} coefficient of the solenoid valve.

5.3.2 Port labeling

K_{VS} 0.3

Inscription	Function
1	Supply air
9	External pilot supply
2	Output
3	Venting

K_{VS} 2.0 and K_{VS} 4.3

i Note

The ports 1 and 9 in the black connecting plate of the solenoid valve are not required and must be sealed using stainless steel blanking plugs.

Inscription	Function
4	Supply air
9	External pilot supply
3/5	Output

5.3.3 Sizing of the connecting line

- ➔ Refer to the table below for the minimum required nominal size of the connecting line at the port 1 of the enclosure.

The specifications apply to a connecting line shorter than 2 m. Use a larger nominal size for lines longer than 2 m.

Connection	9	1
Pipe ¹⁾	6x1 mm	12x1 mm
Hose ²⁾	4x1 mm	9x3 mm

¹⁾ Outside diameter x Wall thickness

²⁾ Inside diameter x Wall thickness

5.3.4 Compressed air quality

NOTICE

Risk of malfunction due to failure to comply with required air quality.

Only use supply air that is dry and free of oil and dust.

Read the maintenance instructions for upstream pressure reducing stations.

Blow through all air pipes and hoses thoroughly before connecting them.

With internal pilot supply over port **1**:

Instrument air (free from corrosive substances), 1.4 to 10 bar operating pressure

With external pilot supply over port **9**

Instrument air (free from corrosive substances) or non-corrosive gases with 0 to 10 bar operating pressure

Compressed air quality according to ISO 8573-1		
Particle size and quantity	Oil content	Pressure dew point
Class 4	Class 3	Class 3
$\leq 5 \mu\text{m}$ and $1000/\text{m}^3$	$\leq 1 \text{ mg}/\text{m}^3$	$-20 \text{ }^\circ\text{C}/10 \text{ K}$ below the lowest ambient temperature to be expected

5.3.5 Pilot supply

K_{vs} 0.3

In the delivered state, the pilot supply is fed internally over port **1**, if not configured otherwise.



Fig. 4: Internal pilot supply

On mounting the solenoid valve to rotary or linear actuators fitted with positioners, change the pilot supply to an external pilot supply over port **9**.

To change to an external supply through port **9**, proceed as follows:

1. Unscrew the fastening screws on the connecting plate.
2. Take the connecting plate off the enclosure.
3. Remove the turnable gasket from the groove and turn it so that the tag points to the right.
4. Refasten the connecting plate.



Fig. 5: External pilot supply

K_{VS} 2.0 and K_{VS} 4.3

i Note

When a booster valve is used (K_{VS} 2.0 and K_{VS} 4.3), the turnable gasket described for K_{VS} 0.3 must always be positioned with its tag pointing to port 1.

In the delivered state, the pilot supply is fed internally over port **4**, if not configured otherwise.

- ➔ On mounting the solenoid valve to rotary or linear actuators fitted with positioners, the pilot supply must be changed to an external pilot supply over port **9**.

To change to an external supply through port **9**, proceed as follows:

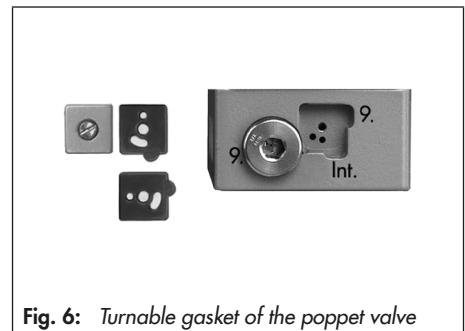

Fig. 6: Turnable gasket of the poppet valve

1. Unscrew the fastening screw from the plate.
2. Remove the plate and turnable gasket from the groove.
3. Turn the turnable gasket by 90° and reinsert it together with the plate into the groove.
4. Tighten the fastening screw.

5.4 Electrical connections

⚠ DANGER

Risk of fatal injury due to the formation of an explosive atmosphere.

For mounting and electrical installation in hazardous areas, observe the explosion protection approvals as well as the relevant electrotechnical regulations and the accident prevention regulations that apply in the country of use.

EN 60079-14 applies in Europe: Electrical installations design, selection and erection. Observe the type of protection and the specific conditions for the type of protection according to the instructions for explosion protection in the appendix of this document.

⚠ WARNING

Incorrect electrical connection will render the explosion protection unsafe.

- Adhere to the terminal assignment and observe correct polarity.*
 - Do not undo the enameled screws.*
 - Do not exceed the maximum permissible values (U_i , I_i , P_i , C_i , L_i) specified in the EC type examination certificates when interconnecting intrinsically safe electrical equipment.*
-

Selecting cables and wires

- Observe the relevant clauses of EN 60079-14 for installation of intrinsically safe circuits.
- Seal cable entries left unused with plugs.

5.4.1 Cable entry with cable gland

The enclosure of the solenoid valve has two M20x1.5 boreholes. They can be fitted with cable glands as required.

- The cable gland version depends on the ambient temperature range. See technical data in section 3.2.
- The screw terminals are designed for wire cross-sections of 0.2 to 2.5 mm². Tighten by at least 0.5 Nm.
- Connect **one** current source at the maximum.
- The solenoid valve must be included in the on-site equipotential bonding system. Connect the conductor outside of the device.

5.4.2 Connecting the power supply

⚠ NOTICE

Risk of malfunction due to incorrect sequence of mounting, installation and start-up.

Observe the following sequence.

- 1. Remove the protective caps from the pneumatic connections.*
- 2. Mount the solenoid valve to the control valve.*
- 3. Connect the supply air.*
- 4. Connect the power supply.*

→ Connect the power supply (voltage) as described in Fig. 7.

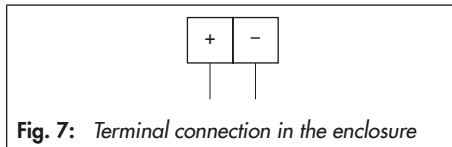

Fig. 7: Terminal connection in the enclosure

6 Operation

The solenoid valve is ready for use when mounting and start-up have been completed.

7 Servicing

i Note

The solenoid valve was checked by SAMSON before it left the factory.

- The product warranty becomes void if service or repair work not described in these instructions is performed without prior agreement by SAMSON's After-sales Service department.*
 - Only use original spare parts by SAMSON, which comply with the original specifications.*
-

7.1 Preparation for return shipment

Defective solenoid valves can be returned to SAMSON for repair.

Proceed as follows to return devices to SAMSON:

1. Decommission the solenoid valve and remove it from the valve.
2. Request a declaration of contamination and fill it out.
3. Send the solenoid valve to SAMSON. The contact information is listed at
▶ www.samsongroup.com > About SAMSON.

8 Malfunctions

8.1 Troubleshooting

Malfunction	Possible reasons	Recommended action
The solenoid valve does not switch.	Incorrect terminal assignment.	Check electrical connection.
	Turn turnable gasket to external pilot supply.	Connect port 9 and supply it with compressed air. Alternatively, turn the turnable gasket to internal pilot supply.
The solenoid valve leaks to the atmosphere.	Gasket slipped.	Check that the formed seal and O-rings are correctly seated.
	Pilot pressure is insufficient and an intermediate position of the solenoid valve is reached (air is constantly vented)	Check the pressure line. Check the pressure line for leakage. Use a larger cross-section for the pressure line.

i Note

Contact SAMSON's After-sales Service department for malfunctions not listed in the table.

8.2 Emergency action

The solenoid valve has a safety function. Upon failure of the supply voltage, it automatically closes (closed in the de-energized state).

The plant operator is responsible for emergency action to be taken in the plant.

9 Decommissioning and removal

⚠ DANGER

Risk of fatal injury due to ineffective explosion protection.

– For mounting and electrical installation in hazardous areas, observe the explosion protection approvals as well as the relevant electrotechnical regulations and the accident prevention regulations that apply in the country of use.

– EN 60079-14 applies in Europe: Electrical installations design, selection and erection

⚠ NOTICE

An interruption will disturb the process.

Do not mount or service the solenoid valve while the process is running and only after isolating the plant by closing the shut-off valves.

9.1 Decommissioning

To decommission the solenoid valve for disassembly, proceed as follows:

1. Disconnect and lock the air supply and pilot supply.
2. Relieve the pipelines completely of pressure.
3. Open the solenoid valve cover and disconnect the wires for the supply voltage.

9.2 Removing the solenoid valve

1. Disconnect the wire for the supply voltage from the solenoid valve.
2. Disconnect the lines for supply air and pilot supply (not required for direct attachment according to VDI/VDE 3847).
3. To remove the positioner, loosen the two fastening screws on the solenoid valve.

9.3 Disposal



We are registered with the German national register for waste electric equipment (stiftung ear) as a producer of electrical and electronic equipment, WEEE reg. no.: DE 62194439

- Observe local, national and international refuse regulations.
- Do not dispose of components, lubricants and hazardous substances together with your other household waste.

💡 Tip

On request, we can appoint a service provider to dismantle and recycle the product.

10 Appendix

10.1 After-sales service

Contact SAMSON's After-sales Service department for support concerning service or repair work or when malfunctions or defects arise.

E-mail address

You can reach the After-sales Service Department at
aftersaleservice@samsongroup.com .

Addresses of SAMSON AG and its subsidiaries

The addresses of SAMSON, its subsidiaries, representatives and service facilities worldwide can be found on our website (▶ www.samsongroup.com) or in all product catalogs.

Required specifications

Please submit the following details:

- Order number and position number in the order
- Type designation and model number or configuration ID
- Other mounted valve accessories (positioner, supply pressure regulator etc.)
- Pressure
- Wire cross-section
- Actuator type and manufacturer

EU DECLARATION OF CONFORMITY TRANSLATION



This declaration of conformity is issued under the sole responsibility of the manufacturer.

Manufacturer:

SAMSON AKTIENGESELLSCHAFT
Weismüllerstraße 3
60314 Frankfurt am Main
Deutschland

Product designation:

Type 3969-110 Solenoid Valve

The product described above is in conformity with the relevant Union harmonisation legislation:

EU Directive	Standards / Technical Specifications
2014/30/EU	EN 61000-6-2:2005 EN 61000-6-3:2007/A1:2011 EN 61326-1:2013
2014/34/EU	EN IEC 60079-0:2018 EN 60079-11:2012
2011/65/EU	EN IEC 63000:2018

Additional information to EU directive 2014/34/EU (ATEX):

The notified body:

TÜV Rheinland Industrie Service GmbH / Identification number 0035
Am Grauen Stein
51105 Köln

Germany

performed the EU Type Approval and issued the certificate TÜV 17 ATEX 8047 X.

Signed for and on behalf of:

Frankfurt am Main, 2024-06-28

Fabio Roma
Vice President Smart Products & Components

Jens Bieger
Director Development Electronics

Revision 01

Classification: Public · SAMSON AKTIENGESELLSCHAFT · Weismüllerstraße 3 · 60314 Frankfurt am Main

Page 1 von 1



1 Safety instructions for ATEX and IECEx

The following safety instructions and safety-related notes must be included in the operating and mounting instructions as required according to Clause 30 of IEC/EN 60079-0 and the Directive 2014/34/EU.

The device must be mounted, started up and serviced by fully trained and qualified personnel only who are familiar with the product; the accepted industry codes and practices are to be observed. According to these mounting and operating instructions, trained personnel refers to individuals who are able to judge the work they are assigned to and recognize possible hazards due to their specialized training, their knowledge and experience as well as their knowledge of the applicable standards.

Explosion-protected versions of this device must be operated only by personnel who has undergone special training or instructions or who is authorized to work on explosion-protected devices in hazardous areas.

To avoid personal injury or property damage, plant operators and operating personnel must prevent hazards that could be caused in the control valve by the process medium, the operating pressure, the signal pressure or by moving parts by taking appropriate precautions. If inadmissible motions or forces are produced in the pneumatic actuator as a result of the supply pressure, it must be restricted using a suitable supply pressure reducing station.

Proper shipping and storage are assumed.

1.1 Electrical connections

⚠ DANGER

Risk of fatal injury due to the formation of an explosive atmosphere.

For mounting and electrical installation in hazardous areas, observe the explosion protection approvals as well as the relevant electrotechnical regulations and the accident prevention regulations that apply in the country of use.

EN 60079-14 applies in Europe: Electrical installations design, selection and erection

⚠ WARNING

Incorrect electrical connection will render the explosion protection unsafe.

Adhere to the terminal assignment and observe correct polarity.

Do not undo the enameled screws.

Do not exceed the maximum permissible values (U_i , I_i , P_i , C_i , L_i) specified in the EC type examination certificates when interconnecting intrinsically safe electrical equipment.



Selecting cables and wires

Observe the relevant clauses of EN 60079-14 for installation of intrinsically safe circuits. Seal cable entries left unused with plugs.

1.2 Servicing explosion-protected devices

If a part of the device on which the explosion protection is based needs to be serviced, the device must not be put back into operation until a qualified inspector has assessed it according to explosion protection requirements, has issued an inspection certificate, or given the device a mark of conformity.

Inspection by a qualified inspector is not required if the manufacturer performs a routine test on the device before putting it back into operation. Document the passing of the routine test by attaching a mark of conformity to the device.

Replace explosion-protected components only with original, routine-tested components by the manufacturer.

Devices that have already been operated outside hazardous areas and are intended for future use inside hazardous areas must comply with the safety requirements placed on serviced devices. Before being operated inside hazardous areas, test the devices according to the specifications for servicing explosion-protected devices.

1.3 Maintenance, calibration and work on equipment

Interconnection with intrinsically safe circuits to check or calibrate the equipment inside or outside hazardous areas is to be performed only with intrinsically safe current/voltage calibrators and measuring instruments to rule out any damage to components relevant to explosion protection.

Observe the maximum permissible values specified in the certificates for intrinsically safe circuits.

Use with flammable gases in hazardous areas

⚠ DANGER

Risk of fatal injury as a result of electrostatic discharge at the device.

In hazardous areas (with type of protection Ex t), mount the device in such a way that electrostatic charging cannot take place.



2 Explosion protection data

ATEX: II 2 G Ex ia IIC T6 Gb
 II 2 D Ex ia IIIC T85°C Db
 II 3 G Ex ec IIC T6 Gc
 II 2 D Ex tb IIIC T 85°C

IECEX: Ex ia IIC T6 Gb
 Ex ia IIIC T85°C Db
 Ex ec IIC T6 Gc
 Ex tb IIIC T 85°C Db

2.1 Signal current circuit

Terminals +/-	
Type of protection:	Ex ia IIC/IIIC Ex ec IIC/IIIC
U_N	14 to 24 V

2.2 Temperatures

2.2.1 Intrinsic safety Ex ia IIC/Ex ec IIC

Temperature class	Permissible ambient temperature T_a
T4	$-45\text{ °C} \leq T_a \leq +80\text{ °C}$
T6	$-45\text{ °C} \leq T_a \leq +70\text{ °C}$

2.2.2 Intrinsic safety Ex ia IIIC

Maximum surface temperature	Permissible ambient temperature T_a
T 85 °C	$-45\text{ °C} \leq T_a \leq +70\text{ °C}$

2.2.3 Intrinsic safety Ex tb IIIC

Maximum surface temperature	Permissible ambient temperature T_a
T 85 °C	$-45\text{ °C} \leq T_a \leq +80\text{ °C}$

i Note

The associated certificates can be found on our website (www.samson.de > Products & Applications > Product selector).

EB 3969 EN



SAMSON AKTIENGESELLSCHAFT
Weismüllerstraße 3 · 60314 Frankfurt am Main, Germany
Phone: +49 69 4009-0 · Fax: +49 69 4009-1507
samson@samsongroup.com · www.samsongroup.com