

# MOUNTING AND OPERATING INSTRUCTIONS

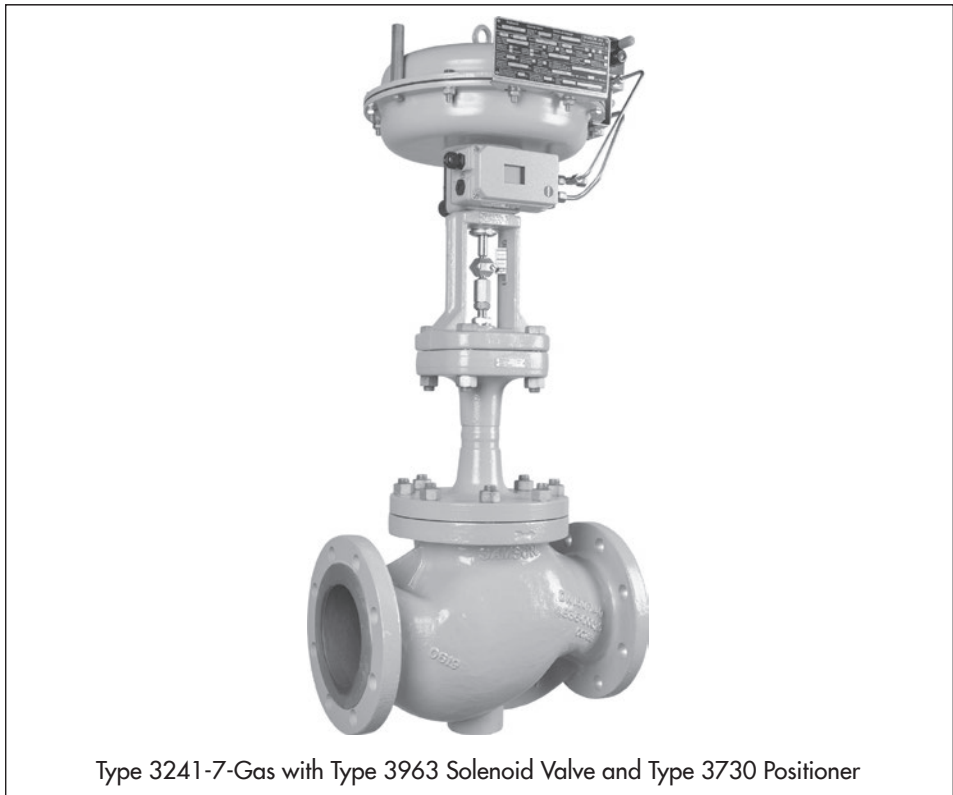

## EB 8020 EN

Translation of original instructions



Type 3241-7-Gas with Type 3963 Solenoid Valve and Type 3730 Positioner

## Automatic Shut-off Valves for Gases

### Type 3241-1-Gas and Type 3241-7-Gas

Valve class D

Edition May 2022



## Note on these mounting and operating instructions

These mounting and operating instructions assist you in mounting and operating the device safely. The instructions are binding for handling SAMSON devices. The images shown in these instructions are for illustration purposes only. The actual product may vary.

- For the safe and proper use of these instructions, read them carefully and keep them for later reference.
- If you have any questions about these instructions, contact SAMSON's After-sales Service (aftersaleservice@samsongroup.com).



Documents relating to the device, such as the mounting and operating instructions, are available on our website at [www.samsongroup.com](http://www.samsongroup.com) > **Service & Support > Downloads > Documentation.**

## Definition of signal words

### **DANGER**

*Hazardous situations which, if not avoided, will result in death or serious injury*

### **WARNING**

*Hazardous situations which, if not avoided, could result in death or serious injury*

### **NOTICE**

*Property damage message or malfunction*

### **Note**

*Additional information*

### **Tip**

*Recommended action*

<b>1</b>	<b>Safety instructions and measures</b> .....	<b>1-1</b>
1.1	Notes on possible severe personal injury .....	1-5
1.2	Notes on possible personal injury .....	1-5
1.3	Notes on possible property damage .....	1-7
1.4	Warnings on the device.....	1-8
<b>2</b>	<b>Markings on the device</b> .....	<b>2-1</b>
2.1	Nameplate for gas version of the control valve .....	2-1
2.2	Valve nameplate .....	2-2
2.3	Actuator nameplate.....	2-3
2.4	DVGW register number.....	2-3
2.5	Material numbers.....	2-3
<b>3</b>	<b>Design and principle of operation</b> .....	<b>3-1</b>
3.1	Versions .....	3-4
3.2	Additional fittings.....	3-4
3.3	Valve accessories .....	3-5
3.4	Technical data .....	3-5
<b>4</b>	<b>Shipment and on-site transport</b> .....	<b>4-1</b>
4.1	Accepting the delivered goods .....	4-1
4.2	Removing the packaging from the valve.....	4-1
4.3	Transporting and lifting the valve.....	4-1
4.3.1	Transporting the valve .....	4-2
4.3.2	Lifting the valve.....	4-3
4.4	Storing the valve .....	4-4
<b>5</b>	<b>Installation</b> .....	<b>5-1</b>
5.1	Installation conditions .....	5-1
5.2	Preparation for installation.....	5-2
5.3	Mounting the valve.....	5-3
5.3.1	Installing the valve into the pipeline .....	5-3
5.4	Testing the installed valve.....	5-4
5.4.1	Vent holes .....	5-5
5.4.2	Leak test .....	5-5
5.4.3	Travel motion .....	5-5
5.4.4	Fail-safe position.....	5-5
5.4.5	Pressure test.....	5-6
<b>6</b>	<b>Start-up</b> .....	<b>6-1</b>
<b>7</b>	<b>Operation</b> .....	<b>7-1</b>

## Contents

<b>8</b>	<b>Malfunctions</b> .....	<b>8-1</b>
8.1	Troubleshooting .....	8-1
8.2	Emergency action .....	8-2
<b>9</b>	<b>Servicing</b> .....	<b>9-1</b>
9.1	Periodic testing .....	9-3
9.2	Preparing the valve for service work .....	9-6
9.3	Completing service work .....	9-6
9.4	Service work.....	9-8
9.4.1	Replacing the gasket .....	9-8
9.4.2	Cleaning the strainer .....	9-8
9.5	Ordering spare parts and operating supplies .....	9-9
<b>10</b>	<b>Decommissioning</b> .....	<b>10-1</b>
<b>11</b>	<b>Removal</b> .....	<b>11-1</b>
11.1	Removing the valve from the pipeline.....	11-1
11.2	Removing the actuator from the valve .....	11-2
<b>12</b>	<b>Repairs</b> .....	<b>12-1</b>
12.1	Returning devices to SAMSON .....	12-1
<b>13</b>	<b>Disposal</b> .....	<b>13-1</b>
<b>14</b>	<b>Certificates</b> .....	<b>14-1</b>
<b>15</b>	<b>Annex</b> .....	<b>15-1</b>
15.1	Tightening torques, lubricants and tools .....	15-1
15.2	Spare parts .....	15-1
15.3	After-sales service .....	15-4

# 1 Safety instructions and measures

## Intended use

The SAMSON Type 3241G Globe Valve in combination with the Type 3271 or Type 3277 Pneumatic Actuator and a solenoid valve is designed to regulate the flow rate, pressure or temperature of fuel gases in gas-consuming equipment. The valve, actuator and solenoid valve are designed to operate under exactly defined conditions (e.g. operating pressure, process medium, temperature). Therefore, operators must ensure that the control valve is only used in applications that meet the specifications used for sizing the valve at the ordering stage. In case operators intend to use the control valve in other applications or conditions than specified, contact SAMSON.

SAMSON does not assume any liability for damage resulting from the failure to use the device for its intended purpose or for damage caused by external forces or any other external factors.

➔ Refer to the technical data and nameplate for limits and fields of application as well as possible uses.

## Reasonably foreseeable misuse

The control valve is not suitable for the following applications:

- Use outside the limits defined during sizing and by the technical data
- Use outside the limits defined by the valve accessories connected to the valve

Furthermore, the following activities do not comply with the intended use:

- Use of non-original spare parts
- Performing service and repair work not described

## Qualifications of operating personnel

The control valve must be mounted, started up, serviced and repaired by fully trained and qualified personnel only; the accepted industry codes and practices must be observed. According to these mounting and operating instructions, trained personnel refers to individuals who are able to judge the work they are assigned to and recognize possible hazards due to their specialized training, their knowledge and experience as well as their knowledge of the applicable standards (e.g. Gas Appliances Regulation (EU) 2016/426). Furthermore, the operating personnel must be specially trained for the correct and safe handling of fuel gases in gas-consuming equipment.

## Safety instructions and measures

Explosion-protected versions of this device must be operated only by personnel who has undergone special training or instructions or who is authorized to work on explosion-protected devices in hazardous areas.

### Personal protective equipment

We recommend checking the hazards posed by the process medium being used (e.g.

▶ GESTIS (CLP) hazardous substances database). Depending on the process medium and/or the activity, the protective equipment required includes:

- Protective clothing, gloves, eye protection and respiratory protection in applications with hot, cold and/or corrosive media
  - Wear hearing protection when working near the valve
  - Hard hat
  - Safety harness when working at height
  - Safety footwear, ESD (electrostatic discharge) footwear, if necessary
- ➔ Check with the plant operator for details on further protective equipment.

### Revisions and other modifications

Revisions, conversions or other modifications of the product are not authorized by SAMSON. They are performed at the user's own risk and may lead to safety hazards, for example. Furthermore, the product may no longer meet the requirements for its intended use.

### Safety features

- Upon supply air or control signal failure, the valve moves to a certain fail-safe position (see 'Design and principle of operation' section). The fail-safe action of the actuator is the same as its direction of action and is specified on the nameplate of SAMSON actuators (see associated actuator documentation).
- **Valve class D:** the safety control valves are tested according to DIN EN 161 (2013-04). In the event of a malfunction, the valves shut off the gas supply. They meet the strict leakage requirements of Class D.

### Warning against residual hazards

To avoid personal injury or property damage, plant operators and operating personnel must prevent hazards that could be caused in the control valve by the process medium, the operating pressure, the signal pressure or by moving parts by taking appropriate precautions. Plant operators and operating personnel must observe all hazard statements, warning and caution notes in these mounting and operating instructions.

Hazards resulting from the special working conditions at the installation site of the valve must be identified in a risk assessment and prevented through the corresponding safety instructions drawn up by the operator.

→ Observe safety measures for handling the device as well as fire prevention and explosion protection measures.

### Responsibilities of the operator

Operators are responsible for proper use and compliance with the safety regulations. Operators are obliged to provide these mounting and operating instructions as well as the referenced documents to the operating personnel and to instruct them in proper operation. Furthermore, operators must ensure that operating personnel or third parties are not exposed to any danger.

Operators are additionally responsible for ensuring that the limits for the product defined in the technical data are observed. This also applies to the start-up and shutdown procedures. Start-up and shutdown procedures fall within the scope of the operator's duties and, as such, are not part of these mounting and operating instructions. SAMSON is unable to make any statements about these procedures since the operative details (e.g. differential pressures and temperatures) vary in each individual case and are only known to the operator.

### Responsibilities of operating personnel

Operating personnel must read and understand these mounting and operating instructions as well as the referenced documents and observe the specified hazard statements, warnings and caution notes. Furthermore, operating personnel must be familiar with the applicable health, safety and accident prevention regulations and comply with them.

### Referenced standards, directives and regulations

- The control valves comply with the requirements of the European Pressure Equipment Directive 2014/68/EU. Valves with a CE marking have a declaration of conformity, which includes information about the applied conformity assessment procedure. The 'Certificates' section contains this declaration of conformity.
- **Valve class D:** the control valves meet the requirements of the previously valid European Gas Appliance Directive 2009/142/EC and the currently valid Gas Appliances Regulation (EU) 2016/426. The EC type examination certificate and EU declaration of conformity are included in the 'Certificates' section.
- The control valves meet the safety, construction and function requirements for automatic shut-off valves with gas burners, gas equipment and similar applications according to DIN EN 161.

## Safety instructions and measures

- According to the ignition hazard assessment performed in accordance with Clause 5.2 of ISO 80079-36, the non-electrical control valves do not have their own potential ignition source even in the rare incident of an operating fault. As a result, they do not fall within the scope of Directive 2014/34/EU.
- ➔ For connection to the equipotential bonding system, observe the requirements specified in section 6.4 of EN 60079-14 (VDE 0165-1).

### Referenced documentation

The following documents apply in addition to these mounting and operating instructions:

- Mounting and operating instructions for the mounted actuator, e.g. ► EB 8310-X for Type 3271 or Type 3277 Pneumatic Actuator
- Mounting and operating instructions for mounted valve accessories (positioner, solenoid valve etc.)
- ► AB 0100 for tools, tightening torques and lubricant



## 1.1 Notes on possible severe personal injury

### DANGER

#### **Risk of bursting in pressure equipment.**

Valves and pipelines are pressure equipment. Impermissible pressure or improper opening can lead to valve components bursting.

- Observe the maximum permissible pressure for valve and plant.
- Before starting any work on the control valve, depressurize all plant sections affected as well as the valve.
- Drain the process medium from all the plant sections concerned as well as the valve.

## 1.2 Notes on possible personal injury

### WARNING

#### **Risk of burn injuries due to hot or cold components and pipelines.**

Depending on the process medium, valve components and pipelines may get very hot or cold and cause burn injuries.

- Allow components and pipelines to cool down or warm up to the ambient temperature.
- Wear protective clothing and safety gloves.

#### **Risk of hearing loss or deafness due to loud noise.**

The noise emissions depend on the valve version, plant facilities and process medium.

- Wear hearing protection when working near the valve.

### **WARNING**

#### **Risk of personal injury due to exhaust air being vented.**

While the valve is operating, air is vented from the actuator, for example, during closed-loop operation or when the valve opens or closes.

- Install the control valve in such a way that vent holes are not located at eye level and the actuator does not vent at eye level in the work position.
- Use suitable silencers and vent plugs.
- Wear eye protection when working in close proximity to the control valve.

#### **Crush hazard arising from moving parts.**

The control valve contains moving parts (actuator and plug stem), which can injure hands or fingers if inserted into the valve.

- Do not insert hands or finger into the yoke while the air supply is connected to the actuator.
- Before working on the control valve, disconnect and lock the pneumatic air supply as well as the control signal.
- Do not impede the movement of the actuator and plug stem by inserting objects into the yoke.
- Before unblocking the actuator and plug stem after they have become blocked (e.g. due to seizing up after remaining in the same position for a long time), release any stored energy in the actuator (e.g. spring compression). See associated actuator documentation.

#### **Risk of personal injury due to preloaded springs.**

Valves in combination with pneumatic actuators with preloaded springs are under tension. These control valves with SAMSON pneumatic actuators can be identified by the long bolts protruding from the bottom of the actuator.

- Before starting any work on the actuator, relieve the compression from the preloaded springs (see associated actuator documentation).

**⚠ WARNING****Risk of personal injury due to residual process medium in the valve.**

While working on the valve, residual medium can flow out of the valve and, depending on its properties, cause personal injury, e.g. (chemical) burns.

- If possible, drain the process medium from all the plant sections affected and the valve.
- Wear protective clothing, safety gloves, respiratory protection and eye protection.

**Risk of personal injury through incorrect operation, use or installation as a result of information on the valve being illegible.**

Over time, markings, labels and nameplates on the valve may become covered with dirt or become illegible in some other way. As a result, hazards may go unnoticed and the necessary instructions not followed. There is a risk of personal injury.

- Keep all relevant markings and inscriptions on the device in a constantly legible state.
- Immediately renew damaged, missing or incorrect nameplates or labels.

## 1.3 Notes on possible property damage

**ⓘ NOTICE****Risk of valve damage due to contamination (e.g. solid particles) in the pipeline.**

The plant operator is responsible for cleaning the pipelines in the plant.

- Flush the pipelines before start-up.

**Risk of valve damage due to unsuitable medium properties.**

The valve is sized according to Gas Appliances Regulation (EU) 2016/426 (valve class D) for fuel gases.

- Only use the process medium specified for sizing the valve.

### ! NOTICE

#### **Risk of leakage and valve damage due to excessively high or low tightening torques.**

Observe the specified torques when tightening control valve components. Excessive tightening torques lead to parts wearing out more quickly. Parts that are too loose may cause leakage.

→ Observe the specified tightening torques (▶ AB 0100).

#### **Risk of valve damage due to the use of unsuitable tools.**

Certain tools are required to work on the valve.

→ Only use tools approved by SAMSON (▶ AB 0100).

#### **Risk of valve damage due to the use of unsuitable lubricants.**

The lubricants to be used depend on the valve material. Unsuitable lubricants may corrode and damage surfaces.

→ Only use lubricants approved by SAMSON (▶ AB 0100).

#### **Risk of the process medium being contaminated through the use of unsuitable lubricants and/or contaminated tools and components.**

→ Keep the valve and the tools used free from solvents and grease.

→ Make sure that only suitable lubricants are used.

## 1.4 Warnings on the device

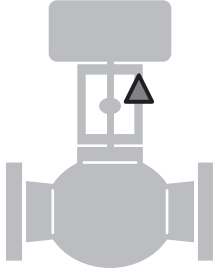
Warning	Meaning of the warning	Location on the device
	Warning against moving parts There is a risk of injury to hands or fingers through the stroking movement of the actuator and plug stem if they are inserted into the yoke while the air supply is connected to the actuator.	

## 2 Markings on the device

### 2.1 Nameplate for gas version of the control valve

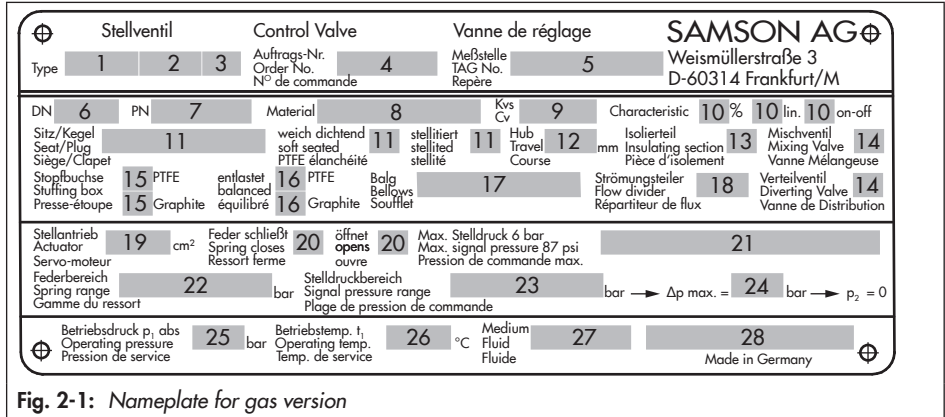

Fig. 2-1: Nameplate for gas version

Item	Inscription meaning
1	Type
2	Configuration ID
3	(empty)
4	Order number
5	Tag no.
6	Valve size: DIN: DN · ANSI: NPS
7	Pressure rating: DIN: PN · ANSI: CL
8	Material
9	Flow coefficient: DIN: K <sub>VS</sub> · ANSI: C <sub>V</sub>
10	Characteristic: %: equal percentage · lin: linear · on-off: on/ off service

Item	Inscription meaning
11	Seat-plug seal: Material Stellite® facing Soft seal with PTFE
12	Valve travel in mm
13	Insulating section
14	Mixing or diverting valve
15	Packing: PTFE Graphite
16	Pressure balancing: PTFE Graphite
17	Bellows material
18	Flow divider
19	Actuator area in cm <sup>2</sup>

Item	Inscription meaning
20	Direction of action Fail-close Fail-open
21	Max. signal pressure in bar
22	Bench range in bar
23	Signal pressure range in bar
24	Max. differential pressure in bar
25	Operating pressure in bar
26	Operating temperature in °C
27	Process medium
28	(empty)

The nameplate for the gas version (210) is affixed to the actuator (see Fig. 2-4).

## 2.2 Valve nameplate



Fig. 2-2: Inscriptions on the valve nameplate

### **i** Note

Fig. 2-1 and the inscription table list all possible characteristics and options that may appear on a valve nameplate. Only the inscriptions relevant to the ordered Type 3241G Valve actually appear on the nameplate.

Item	Inscription meaning
1	Data Matrix code
2	Type designation
4	Material
5	Month and year of manufacture
6	Valve size: DIN: <b>DN</b> · ANSI: <b>NPS</b> · JIS: <b>DN</b>
7	Pressure rating: DIN: <b>PN</b> · ANSI: <b>CL</b> · JIS: <b>K</b>
8	Order number/item
10	Flow coefficient: DIN: <b>KVS</b> · ANSI: <b>CV</b>
11	Characteristic: %: equal percentage · <b>LIN</b> : linear <b>mod-lin</b> : modified linear <b>NO/NC</b> : on/off service
12	Seat-plug seal: <b>ME</b> : metal · <b>HA</b> : carbide metal <b>ST</b> : metal Base material with Stellite® facing <b>KE</b> : ceramic · <b>PT</b> : PTFE soft seal · <b>PK</b> : PEEK soft seal
13	Seat code (trim material): on request
14	Pressure balancing: DIN: <b>D</b> · ANSI/JIS: <b>B</b> Version: <b>M</b> : mixing valve · <b>V</b> : flow-diverting valve

Item	Inscription meaning
15	Noise reduction: <b>1</b> : flow divider (ST) 1 · <b>2</b> : ST 2 · <b>3</b> : ST 3 <b>1/PSA</b> : ST 1 standard and integrated in seat for PSA valve <b>AC-1/AC-2/AC-3/AC-5</b> : AC trim, versions 1 to 5 · <b>LK</b> : perforated plug · <b>LK1/LK2/LK3</b> : perforated plug with flow divider ST 1 to ST 3 · <b>MHC1</b> : multi-hole cage · <b>CC1</b> : Combi Cage · <b>ZT1</b> : Zero Travel
16	Country of origin
17	PSA version: <b>PSA</b>
18	Cage/seat style: <b>CC</b> : clamped cage, clamped seat <b>SF</b> : suspended cage, flanged seat
19	CE marking
20	ID of the notified body <b>PED</b> : Pressure Equipment Directive <b>G1/G2</b> : gases and vapors Fluid group 1 = hazardous Fluid group 2 = other <b>L1</b> : liquids Fluid group 1 = hazardous Fluid group 2 = other <b>I/II/III</b> : Category 1 to 3
21	Serial number
22	NE 53 (NAMUR Recommendation)

The valve nameplate (80) is affixed to the flange (see Fig. 2-4).

## 2.3 Actuator nameplate

See associated actuator documentation.

The actuator nameplate (A100) is stuck on the diaphragm casing (see Fig. 2-4).

## 2.4 DVGW register number

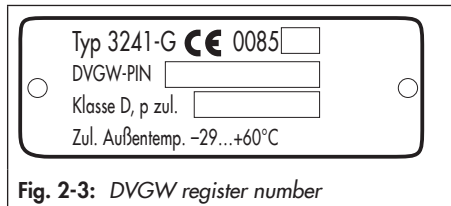

Fig. 2-3: DVGW register number

The plate with the DVGW register number (212) is affixed to the bellows seal (see Fig. 2-4).

## 2.5 Material identification numbers

The seat and plug of the valves have an item number written on them. You can contact us stating this item number to find out which material is used. Additionally, a seat code is used to identify the trim material. This seat code is specified on the valve nameplate.

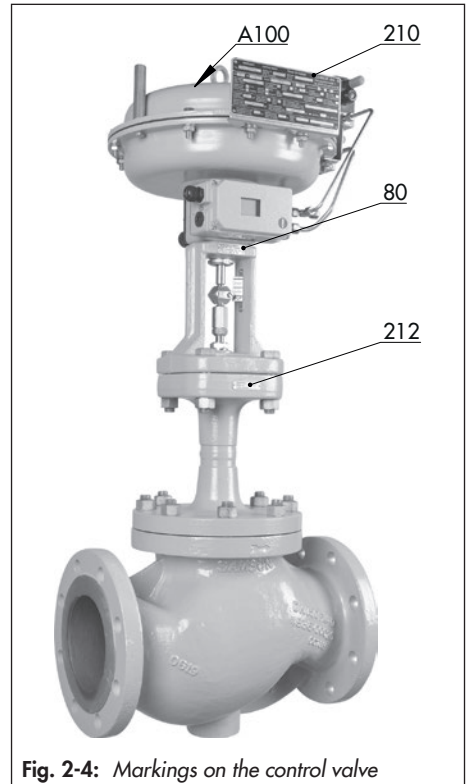

Fig. 2-4: Markings on the control valve





### 3 Design and principle of operation

See Fig. 3-1

The seat (4) and plug with plug stem (5) are installed in the body (1). The plug stem is screwed to the plug stem with bellows seal (37). The plug stem is sealed by the metal bellows and the packing (15). The stem connector clamps (A26/27) connect the actuator stem (A7) of the mounted actuator.

The bellows seal (22) is fitted with a test connection (42). It can be used to monitor the sealing ability of the bellows.

A strainer installed upstream of the valve body. It prevents solid particles in the process medium from damaging the valve. The strainer is not required when a central strainer facility is installed.

The springs in the pneumatic actuator are located either above or below the diaphragm depending on the selected fail-safe action. A change in the signal pressure acting on the diaphragm causes the plug to move. The actuator size is determined by the diaphragm area.

The process medium flows through the strainer and the valve in the direction indicated by the arrow. A rise in signal pressure causes the force acting on the diaphragm in the actuator to increase. The springs are compressed. Depending on the selected direction of action, the actuator stem retracts or extends. As a result, the plug position in the seat changes and determines the flow rate through the valve.

The signal pressure  $p_{st}$  is applied to the pilot valve whose coil is connected to the safety interlock circuit (switch 14, Fig. 3-2 and Fig. 3-3). During operation, the coil is energized and the signal pressure  $p_{st}$  acts on the diaphragm. In the event of a malfunction, the pilot valve is activated and the pressure acting on the diaphragm is relieved, causing the control valve to quickly close.

## Design and principle of operation

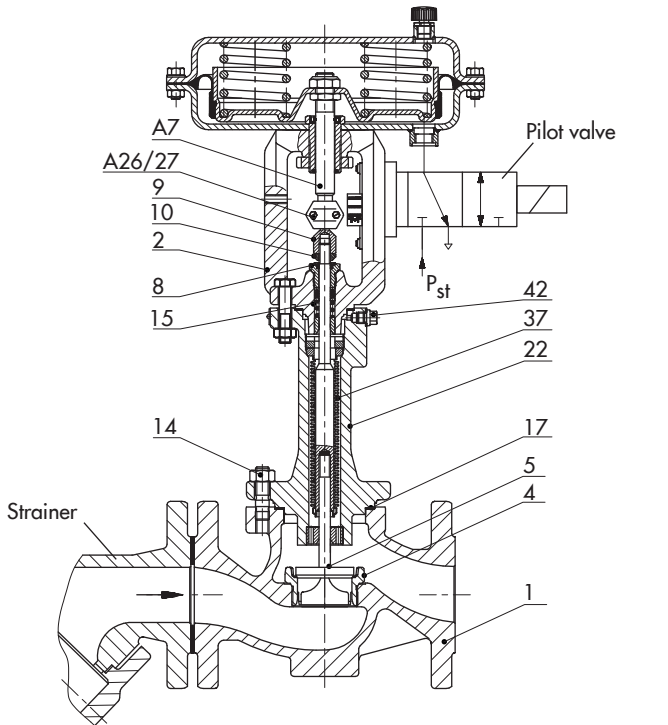

- |    |                                |        |                              |
|----|--------------------------------|--------|------------------------------|
| 1  | Body                           | 15     | Packing                      |
| 2  | Flange                         | 17     | Body gasket                  |
| 4  | Seat                           | 22     | Bellows seal                 |
| 5  | Plug (with plug stem)          | 37     | Plug stem with metal bellows |
| 8  | Threaded bushing (packing nut) | 42     | Test connection              |
| 9  | Stem connector nut             | A7     | Actuator stem                |
| 10 | Lock nut                       | A26/27 | Stem connector clamps        |
| 14 | Body nut                       |        |                              |

**Fig. 3-1:** Type 3241-1-Gas Automatic Shut-off Valve

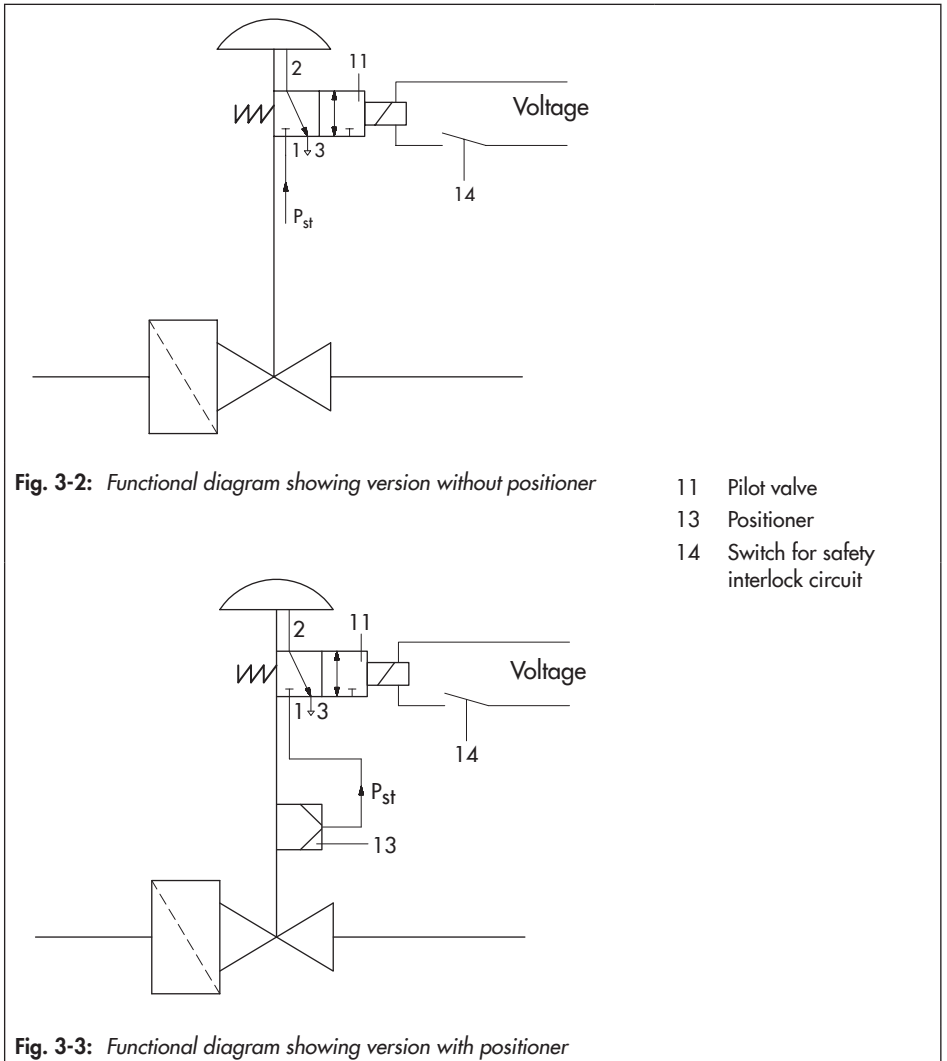

## Design and principle of operation

### Fail-safe action

The fail-safe position depends on the actuator used. See associated actuator documentation.

Depending on how the compression springs are arranged in the SAMSON Type 3271 and Type 3277 Pneumatic Actuator, the valve has one of two different fail-safe positions:

#### – Actuator stem extends (FA)

When the signal pressure is reduced or the air supply fails, the springs move the actuator stem downward and close the valve. The valve opens when the signal pressure is increased enough to overcome the force exerted by the springs.

#### – Actuator stem retracts (FE)

When the signal pressure is reduced or the air supply fails, the springs move the actuator stem upwards and open the valve. The valve closes when the signal pressure is increased enough to overcome the force exerted by the springs.

---

#### **i** Note

*The "actuator stem extends" direction of action is only permitted for the Type 3241G Valve in valve class D (see Table 3-3).*

---

## 3.1 Versions

### Actuators

➔ To select a suitable actuator, see Table 3-3 (valve class D).

## 3.2 Additional fittings

### Strainer

Install a strainer or a central strainer facility upstream of the valve body. It prevents solid particles in the process medium from damaging the valve.

---

#### **i** Note

*For special versions made of A216 WCC or A351 CF8M in Class 300: as a DIN version of the Type 2 NI Strainer is only available, a central strainer facility must be installed when an ANSI version is used.*

---

### Insulation

Control valves can be insulated to reduce heat energy transfer.

Refer to the instructions in the 'Installation' section.

### Test connection

Versions with bellows seal fitted with a test connection (G 1/8) at the top flange allow the sealing ability of the bellows to be monitored.

### Safety guard

For operating conditions that require increased safety (e.g. in cases where the valve is freely accessible to untrained staff), a safety guard must be installed to rule out a crush hazard arising from moving parts (actuator and plug stem). Plant operators are responsible for deciding whether a guard is to be used. The decision is based on the risk posed by the plant and its operating conditions.

**Noise emissions**

Trims with flow dividers can be used to reduce noise emission (see ► T 8081).

**3.3 Valve accessories**

Information Sheet ► T 8350

**3.4 Technical data**

The nameplates provide information on the control valve version. See the 'Markings on the device' section.

**i Note**

*More information is available in Data Sheet ► T 8020-2.*

**DIN DVGW test mark**

The valves were typetested by TÜV (German technical surveillance association) and received the test mark by DVGW (German Technical and Scientific Association for Gas and Water) as specified in Table 3-2.

**Conformity**

The Type 3241G Valve bears the CE mark of conformity:

**Temperature range**

Depending on the version, the control valve is designed for a temperature range from -20 to +220 °C.

**Leakage class**

Leakage class according to DIN EN 161

**Noise emissions**

SAMSON is unable to make general statements about noise emissions. The noise emissions depend on the valve version, plant facilities and process medium.

## Design and principle of operation

**Table 3-1:** Materials (material numbers according to DIN EN)

Valve	DN 15 to 150		DN 15 to 80		Strainer	
Body <sup>1)</sup>	Cast steel 1.0619	Cast stainless steel 1.4408	Forged steel 1.0460	Forged stain- less steel 1.4571	Cast steel 1.0619	Cast stainless steel 1.4408
Valve bonnet	1.0460	1.4404	1.0460	1.4404	Standard strainer insert and dual strainer insert 1.4401	
Seat and plug	1.4404 Plug with soft seal, PTFE seal with 15 % glass fiber					
Guide bushing	1.4104	1.4404	1.4104	1.4404		
Packing	V-ring packing: PTFE with carbon · Spring: 1.4310					
Intermediate piece	1.0460	1.4404	1.0460	1.4404		
Metal bellows	1.4571					
Body gaskets	Graphite on metal core					

<sup>1)</sup> Special version: A216 WCC or A351 CF8M in Class 300. As a DIN version of the Type 2 NI Strainer is only available, a central strainer facility must be installed.

**Table 3-2:** Type 3241G Valve · Cast body: DN 15 to 150 · Forged body: DN 15 to 80

DIN DVGW test mark		CE-0085CQ0516																				
Valve size	DN	15			25			40			50			80			100			150		
Pressure rating	PN	40																				
K <sub>VS</sub> coefficient (without flow divider ST 1)		0.4	1.6	0.4	1.6	6.3	6.3	16	6.3	16	25	40	25	40	60	80	63	100	160	160	260	
		0.63	2.5	0.63	2.5	10	10	-	10	-	-	-	-	-	-	-	-	-	-	-	-	
		1.0	4.0	1.0	4.0	-	-	-	-	-	-	-	-	-	-	-	-	-	-	-	-	
K <sub>VS</sub> -ST 1		-	-	-	-	-	-	-	-	22	36	22	36	54	72	57	90	144	144	234		
Seat diameter	mm	6	12	6	12	24	24	31	24	31	38	48	38	48	63	80	63	80	100	100	130	
Permissible differential/operating pressure	bar	20									15			10			5					
Rated travel	mm	15												30								
Rangeability		50 : 1									30 : 1											
Perm. ambient temperature		-40 to +60 °C																				
Perm. medium temperature		-20 to +220 °C																				
Closing time		<5 s <sup>1)</sup>																				
Valve class		Valve class D																				
Strainer		Type 2 NI, special version for gas, 0.25 mm mesh size																				

<sup>1)</sup> Closing time <1 s when fitted with correspondingly sized pilot valves (possibly in combination with a quick exhaust valve)

**Table 3-3:** Types 3271 and 3277 Pneumatic Actuators

Actuator area in cm <sup>2</sup>		175				355					750		
Bench range	bar	0.8 to 2.4		1.7 to 3.3		2.35 to 2.95					1.6 to 2.4	1.65 to 2.65	
Required supply pressure	bar	2.7		3.6		3.25	3.3	3.25	3.3	3.25	2.7	3	2.95
Max. supply pressure	bar	6				6					6		
Closing force	kN	1.4		3		8.34	8.3	8.34	8.3	8.34	12		12.4
Fail-safe position		Fail-close											

## Design and principle of operation

**Table 3-4:** Pilot valves for Type 3241-1-Gas · Valid for closing time <5 s

Valve			Solenoid valve manufacturer and model number			
Valve size DN	Actuator area [cm <sup>2</sup> ]	Fail-safe position	SAMSOMATIC model K <sub>VS</sub> coefficient (Attachment: threaded connection)		Norgren series Herion (Attachment: NAMUR interface)	
			3963-xxxxx13 1.4	3963-xxxxx14 4.3	24011 <sup>1)</sup>	98015
15	175	Stem extends (FA) Fail-close	•	•	•	•
25	175		•	•	•	•
40	175		•	•	•	•
50	175		•	•	•	•
	355		•	•	•	•
80	355		•	•	•	•
	750		•	•	•	•
100	750		•	•	•	•
150	750		•	•	•	•

<sup>1)</sup> Herion Type 24011 Solenoid valve with quick exhaust module



### Dimensions and weights

Table 3-5 to Table 3-7 provide an overview of the dimensions and weights of the standard version of Type 3241G Valve.

**Table 3-5: Dimensions for Type 3241G Valve**

Valve	DN	15	25	40	50	80	100 <sup>1)</sup>	150 <sup>1)</sup>	
Length L	mm	130	160	200	230	310	350	480	
Length L1	mm	260	320	400	460	620	700	960	
Height H1 with 175, 355 and 750 cm <sup>2</sup> actuator area	mm	222		223		262	354	390	
H2 <sup>2)</sup>	Cast steel	mm	47.5	57.5	75	82.5	100	118 <sup>3)</sup>	175 <sup>3)</sup>
	Forged steel	mm	53 <sup>3)</sup>	70 <sup>3)</sup>	94 <sup>3)</sup>	100 <sup>3)</sup>	132 <sup>3)</sup>	-	

1) Only with valve body made of 1.0619 or 1.4408

2) The H2 dimension is the distance from the middle of the flow path to the lowest point of the valve. This point may be the bottom of the connecting flange or the bottom of the valve body.

3) Contrary to the drawing, the lowest point is the bottom of the valve body.

**Table 3-6: Dimensions for Types 3271 and 3277 Pneumatic Actuators**

Actuator area	cm <sup>2</sup>	175v2	240	350	355v2	700	750v2
Diaphragm ØD	mm	215	240	280	280	390	394
H <sup>1)</sup>	mm	78	62	82	121	199	236
H3 <sup>2)</sup>	mm	110	110	110	110	190	190
H5	Type 3277 mm	101	101	101	101	101	101
Thread	Type 3271	M30x1.5					
	Type 3277	M30x1.5					
α	Type 3271	G ¼ (¼ NPT)	G ¼ (¼ NPT)	G ⅜ (⅜ NPT)	G ⅜ (⅜ NPT)	G ⅜ (⅜ NPT)	G ⅜ (⅜ NPT)
α2	Type 3277	G ⅜	G ⅜	G ⅜	G ⅜	G ⅜	G ⅜

1) Height with welded-on lifting eyelet or height of eyebolt according to DIN 580. Height of the swivel hoist may differ. Actuators up to 355v2 cm<sup>2</sup> without lifting eyelet

2) Minimum clearance to remove actuator due to solenoid valve and bracket

## Design and principle of operation

**Table 3-7: Weights**

Valve	DN	15	25	40	50	80	100	150
Weight without actuator	kg (approx.)	8	10	18	21	38	60	150
<b>Strainer</b>								
Weight	kg (approx.)	2	4	7	10	19	28	60
Actuator	cm <sup>2</sup>	175v2	240	350	355v2	700	750v2	
Weight of Type 3271	kg (approx.)	6	5	8	15	22	36	
Weight of Type 3277	kg (approx.)	10	9	12	19	26	40	
<b>Solenoid valve</b>	kg (approx.)	1						

### Dimensional drawings

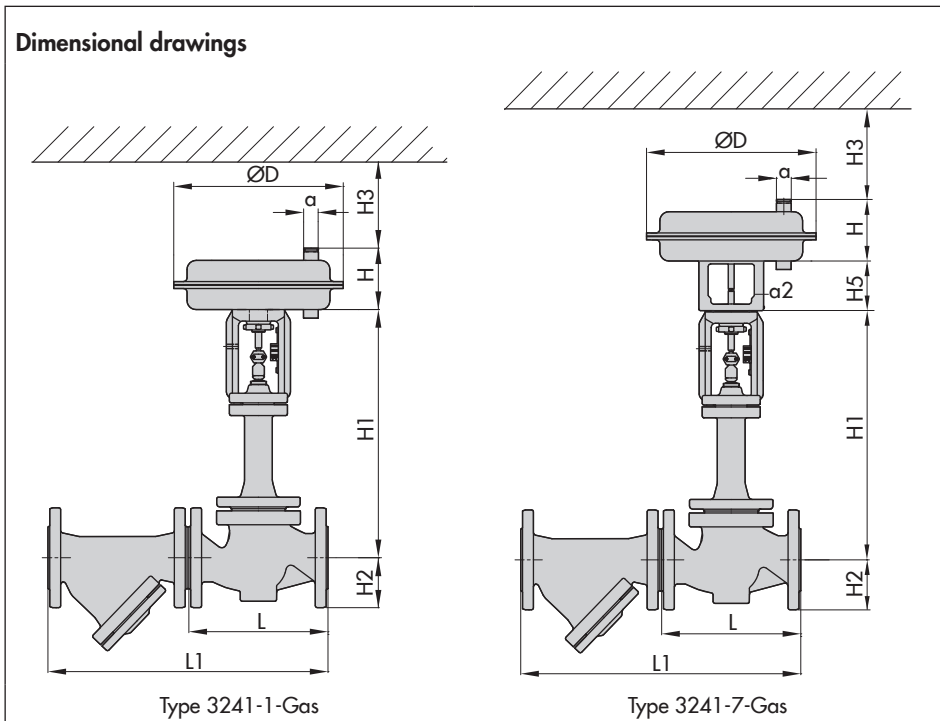

## 4 Shipment and on-site transport

The work described in this section is only to be performed by personnel appropriately qualified to carry out such tasks.

### 4.1 Accepting the delivered goods

After receiving the shipment, proceed as follows:

1. Check the scope of delivery. Check that the specifications on the valve nameplate match the specifications in the delivery note. See the 'Markings on the device' section for nameplate details.
2. Check the shipment for transportation damage. Report any damage to SAMSON and the forwarding agent (refer to delivery note).
3. Determine the weight and dimensions of the units to be lifted and transported in order to select the appropriate lifting equipment and lifting accessories. Refer to the transport documents and the 'Technical data' section.

### 4.2 Removing the packaging from the valve

Observe the following sequence:

- Do not open or remove the packaging until immediately before lifting to install the valve into the pipeline.

- Leave the control valve in its transport container or on the pallet to transport it on site.
- Do not remove the protective caps from the inlet and outlet until immediately before installing the valve into the pipeline. They prevent foreign particles from entering the valve.
- Dispose and recycle the packaging in accordance with the local regulations.

### 4.3 Transporting and lifting the valve

---

#### **⚠ DANGER**

***Danger due to suspended loads falling.***

- *Stay clear of suspended or moving loads.*
  - *Close off and secure the transport paths.*
- 

#### **⚠ WARNING**

***Risk of lifting equipment tipping over and risk of damage to lifting accessories due to exceeding the rated lifting capacity.***

- *Only use approved lifting equipment and accessories whose minimum lifting capacity is higher than the weight of the valve (including actuator and packaging, if applicable).*
-

### WARNING

**Risk of personal injury due to the control valve tipping over.**

- Observe the valve's center of gravity.
- Secure the valve against tipping over or turning.

### WARNING

**Risk of injury due to incorrect lifting without the use of lifting equipment.**

Lifting the control valve without the use of lifting equipment may lead to injuries (back injury in particular) depending on the weight of the control valve.

- Observe the occupational health and safety regulations valid in the country of use.

### NOTICE

**Risk of valve damage due to incorrectly attached slings.**

The lifting eyelet/eyebolt on SAMSON actuators is only intended for mounting and removing the actuator as well as lifting the actuator without valve. Do not use this lashing point to lift the entire control valve assembly.

- When lifting the control valve, make sure that the slings attached to the valve body bear the entire load.
- Do not attach load-bearing slings to the actuator or any other parts.
- Observe lifting instructions (see section 4.3.2).

### Tip

A swivel hoist can be screwed into SAMSON actuators with a female thread on the top diaphragm case in place of the eye-bolt (see associated actuator documentation).

In contrast to the lifting eyelet/eyebolt, the swivel hoist is designed for setting a control valve assembly upright.

The sling between the swivel hoist and rigging equipment (hook, shackle etc.) must not bear any load when lifting a control valve assembly. The sling only protects the control valve from tilting while being lifted.

### Tip

Our after-sales service can provide more detailed transport and lifting instructions on request.

## 4.3.1 Transporting the valve

The control valve can be transported using lifting equipment (e.g. crane or forklift).

- Leave the control valve in its transport container or on the pallet to transport it.
- Observe the transport instructions.

### Transport instructions

- Protect the control valve against external influences (e.g. impact).
- Do not damage the corrosion protection (paint, surface coatings). Repair any damage immediately.

- Protect the piping and any mounted valve accessories against damage.
- Protect the control valve against moisture and dirt.
- The permissible transportation temperature of standard control valves is  $-20$  to  $+65$  °C.

**i Note**

Contact our after-sales service for the transportation temperatures of other valve versions.

### 4.3.2 Lifting the valve

To install a large valve into the pipeline, use lifting equipment (e.g. crane or forklift) to lift it.

#### Lifting instructions

- Use a hook with safety latch (see Fig. 4-1) to secure the slings from slipping off the hook during lifting and transporting.
- Secure slings against slipping.
- Make sure the slings can be removed from the valve once it has been installed into the pipeline.
- Prevent the control valve from tilting or tipping over.

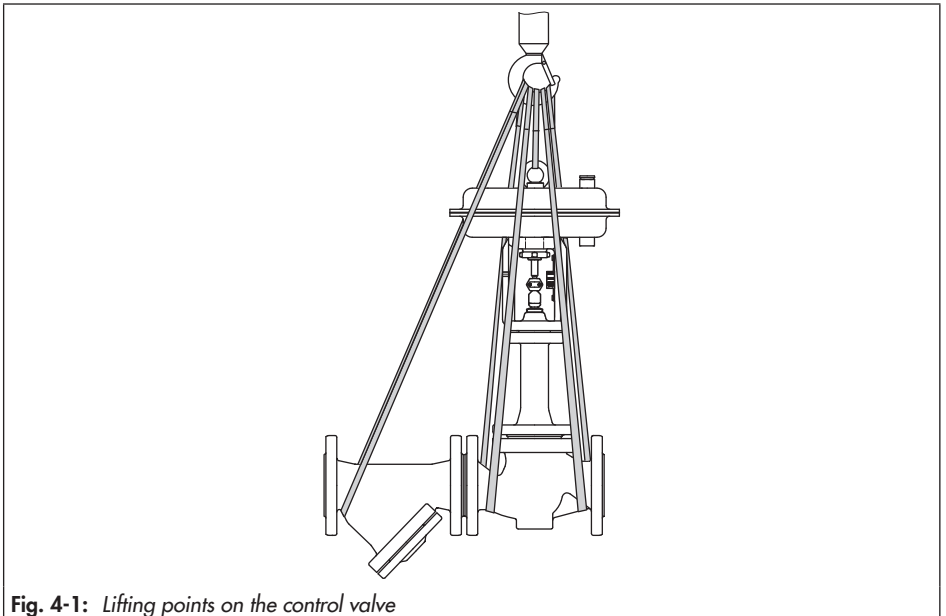

Fig. 4-1: Lifting points on the control valve

## Shipment and on-site transport

- Do not leave loads suspended when interrupting work for longer periods of time.
- Make sure that the axis of the pipeline is always horizontal during lifting and the axis of the plug stem is always vertical.
- Make sure that the additional sling between the lashing point on the actuator and rigging equipment (hook, shackle etc.) does not bear any load when lifting actuators with an actuator area of 700 cm<sup>2</sup> or larger. The sling only protects the control valve from tilting while being lifted. Before lifting the control valve, tighten the sling.
- Make sure that the sling around the strainer is long enough and that the load that it bears is not too heavy. The sling must not bend the strainer upwards and not place strain on the flanged joint. Attach one sling to each flange of the body and to the rigging equipment of the crane or forklift (see Fig. 4-1).

### Lifting the control valve

1. Attach one sling to each flange of the body and to the rigging equipment (e.g. hook) of the crane or forklift (see Fig. 4-1).
2. **700 cm<sup>2</sup> actuator area and larger:** attach another sling to the lashing point on the actuator and to the rigging equipment.
3. Attach another sling to the flange of the strainer.

4. Carefully lift the control valve. Check whether the lifting equipment and accessories can bear the weight.
5. Move the control valve at an even pace to the site of installation.
6. Install the valve into the pipeline (see the 'Installation' section).
7. After installation in the pipeline, check whether the flanges are bolted tight and the valve in the pipeline holds.
8. Remove slings.

## 4.4 Storing the valve

---

### ⓘ NOTICE

**Risk of valve damage due to improper storage.**

- Observe the storage instructions.
  - Avoid long storage times.
  - Contact SAMSON in case of different storage conditions or longer storage times.
- 

### ⓘ Note

We recommend regularly checking the control valve and the prevailing storage conditions during long storage periods.

---

### Storage instructions

- Protect the control valve against external influences (e.g. impact).
- Secure the valve in the stored position against slipping or tipping over.

- Do not damage the corrosion protection (paint, surface coatings). Repair any damage immediately.
- Protect the control valve against moisture and dirt. Store it at a relative humidity of less than 75 %. In damp spaces, prevent condensation. If necessary, use a drying agent or heating.
- Make sure that the ambient air is free of acids or other corrosive media.
- The permissible storage temperature of standard control valves is  $-20$  to  $+65$  °C. Contact our after-sales service for the storage temperatures of other valve versions.
- Do not place any objects on the control valve.

### Special storage instructions for elastomers

Elastomer, e.g. actuator diaphragm

- To keep elastomers in shape and to prevent cracking, do not bend them or hang them up.
- We recommend a storage temperature of  $15$  °C for elastomers.
- Store elastomers away from lubricants, chemicals, solutions and fuels.



*Our after-sales service can provide more detailed storage instructions on request.*

---





## 5 Installation

The work described in this section is only to be performed by personnel appropriately qualified to carry out such tasks.

### 5.1 Installation conditions

#### Work position

The work position for the control valve is the front view looking onto the operating controls (including valve accessories).

Plant operators must ensure that, after installation of the device, the operating personnel can perform all necessary work safely and easily access the device from the work position.

#### Pipeline routing

The inlet and outlet lengths (see Table 5-1) vary depending on several variables and process conditions and are intended as rec-

ommendations. Contact SAMSON if the lengths are significantly shorter than the recommended lengths.

To ensure that the valve functions properly, proceed as follows:

- ➔ Observe the inlet and outlet lengths (see Table 5-1). Contact SAMSON if the valve conditions or states of the medium process deviate.
- ➔ Install the valve free of stress and with the least amount of vibrations as possible. Read information under 'Mounting position' and 'Support or suspension' in this section.
- ➔ Install the valve allowing sufficient space to remove the actuator and valve or to perform service work on them.

#### Mounting position

Generally, we recommend installing the valve with the actuator upright and on top of the valve.

Table 5-1: Inlet and outlet lengths

State of process medium	Valve conditions	Inlet length a	Outlet length b
Gas	$Ma \leq 0.3$	2	4
	$0.3 \leq Ma \leq 0.7$	2	10

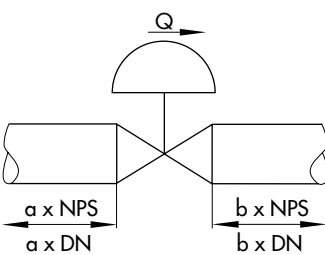

Q Flow rate  
a Inlet length  
b Outlet length

## Installation

- Contact SAMSON if the mounting position is not as specified above.

### Support or suspension

---

#### **i** Note

*The plant engineering company is responsible for selecting and implementing a suitable support or suspension of the installed control valve and the pipeline.*

---

Depending on the valve version and mounting position, the valve, actuator and pipeline must be supported or suspended.

Valves, which are not installed in the pipeline in the upright position with the actuator on top, must be supported or suspended.

### Valve accessories

- During connection of valve accessories, make sure that they are easily accessible and can be operated safely from the work position.

### Vent plugs

Vent plugs are screwed into the exhaust air ports of pneumatic and electropneumatic devices. They ensure that any exhaust air that forms can be vented to the atmosphere (to avoid excess pressure in the device). Furthermore, the vent plugs allow air intake to prevent a vacuum from forming in the device.

- Locate the vent plug on the opposite side to the work position of operating personnel.

## 5.2 Preparation for installation

Before installation, make sure the following conditions are met:

- The valve is clean.
- The valve and all valve accessories (including piping) are not damaged.
- The valve data on the nameplate (type designation, valve size, material, pressure rating and temperature range) match the plant conditions (size and pressure rating of the pipeline, medium temperature etc.). See the 'Markings on the device' section for nameplate details.
- The requested or required additional pipe fittings (see 'Additional fittings' in the 'Design and principle of operation' section) have been installed or prepared as necessary before installing the valve.

---

#### **!** NOTICE

**Risk of control valve damage due to incorrect insulation.**

- *Only insulate control valves with bellows seal up to the bonnet flange of the valve body for medium temperatures below 0 °C and above 220 °C. If the bellows seal is insulated, it will not function properly.*
- 

Proceed as follows:

- Lay out the necessary material and tools to have them ready during installation work.
- Flush the pipelines.

**i Note**

The plant operator is responsible for cleaning the pipelines in the plant.

- Check any mounted pressure gauges to make sure they function properly.
- When the valve and actuator are already assembled, check the tightening torques of the bolted joints (▶ AB 0100). Components may loosen during transport.

### 5.3 Mounting the valve

SAMSON Type 3241G Valves are delivered ready for use. Valve and actuator are delivered ready mounted. The activities listed below are necessary to install the valve and before it can be started up.

**ⓘ NOTICE**

**Risk of valve damage due to excessively high or low tightening torques.**

Observe the specified torques when tightening control valve components. Excessive tightening torques lead to parts wearing out more quickly. Parts that are too loose may cause leakage.

- Observe the specified tightening torques (▶ AB 0100).

**ⓘ NOTICE**

**Risk of valve damage due to the use of unsuitable tools.**

- Only use tools approved by SAMSON (▶ AB 0100).

### 5.3.1 Installing the valve into the pipeline

**ⓘ NOTICE**

**Premature wear and leakage due to insufficient support or suspension.**

- Support or suspend the valve sufficiently at suitable points.

1. Close the shut-off valves in the pipeline at the inlet and outlet of the plant section while the valve is being installed.
2. Prepare the relevant section of the pipeline for installing the valve.
3. Remove the protective caps from the valve ports before installing the valve.
4. Lift the valve using suitable lifting equipment to the site of installation (see information under 'Lifting the valve' in the 'Shipment and on-site transport' section). Observe the flow direction through the valve. The arrow on the valve indicates the direction of flow.
5. Make sure that the correct flange gaskets are used.
6. Bolt the pipe to the valve free of stress.
7. Attach a support or suspension on the valve, if necessary.

## 5.4 Testing the installed valve

### **⚠ DANGER**

**Risk of bursting due to incorrect opening of pressurized equipment or components.**

Valves and pipelines are pressure equipment that may burst when handled incorrectly.

Flying projectile fragments or the release of process medium under pressure can cause serious injury or even death.

Before working on the control valve:

- Depressurize all plant sections affected and the valve (including the actuator). Release any stored energy.
- Drain the process medium from all the plant sections concerned as well as the valve.

### **⚠ WARNING**

**Risk of personal injury due to pressurized components and process medium being discharged.**

- Do not loosen the screw of the test connection while the valve is pressurized.

### **⚠ WARNING**

**Risk of hearing loss or deafness due to loud noise.**

Noise emission (e.g. cavitation or flashing) may occur during operation caused by the process medium and the operating conditions. Additionally, a loud noise may briefly occur through the sudden venting of the pneumatic actuator or pneumatic valve accessories not fitted with noise-reducing fittings. Both can damage hearing.

cessories not fitted with noise-reducing fittings. Both can damage hearing.

- Wear hearing protection when working near the valve.

### **⚠ WARNING**

**Crush hazard arising from actuator and plug stem moving.**

- Do not insert hands or finger into the yoke while the air supply is connected to the actuator.
- Before working on the control valve, disconnect and lock the pneumatic air supply as well as the control signal.
- Do not impede the movement of the actuator and plug stem by inserting objects into the yoke.
- Before unblocking the actuator and plug stem after they have become blocked (e.g. due to seizing up after remaining in the same position for a long time), release any stored energy in the actuator (e.g. spring compression). See associated actuator documentation.

### **⚠ WARNING**

**Risk of personal injury due to exhaust air being vented.**

While the valve is operating, air is vented from the actuator, for example, during closed-loop operation or when the valve opens or closes.

- Wear eye protection when working in close proximity to the control valve.

**⚠ WARNING****Risk of personal injury due to preloaded springs.**

Actuators with preloaded springs are under tension. They can be identified by the long bolts protruding from the bottom of the actuator.

→ Before starting any work on the actuator, relieve the compression from the preloaded springs (see associated actuator documentation).

SAMSON valves are delivered ready for use. To test the valve functioning before start-up or putting back the valve into operation, perform the following tests:

**5.4.1 Vent holes**

- Check the vent of the pilot valve. The vent hole must remain open.
- Check the pressure connection on the top diaphragm case of the actuator. The pressure connection must remain open.

**5.4.2 Leak test**

The plant operator is responsible for performing the leak tests and selecting the test methods. The leak tests must comply with the requirements of the national and international standards that apply at the site of installation.



*Our after-sales service can support you to plan and perform a leak test for your plant.*

1. Close the valve.
  2. Slowly apply the test medium to the inlet space upstream of the valve. A sudden surge in pressure and resulting high flow velocities can damage the valve.
  3. Open the valve.
  4. Apply the required test pressure.
  5. Check the leakage rate as specified in Table 3 of DIN EN 13611.
  6. Depressurize the pipeline section and valve.
  7. Rework any parts that leak and repeat the leak test.
- When the leak test is not passed:
- Do **not** put the valve into operation.
  - Contact SAMSON's After-sales Service.

**5.4.3 Travel motion**

The movement of the actuator stem must be linear and smooth.

- Apply the maximum and minimum control signals to check the end positions of the valve while observing the movement of the actuator stem.
- Check the travel reading at the travel indicator scale.

**5.4.4 Fail-safe position**

- Shut off the signal pressure line.
- Check whether the valve moves to the fail-safe position (see the 'Design and principle of operation' section).

### 5.4.5 Pressure test

The plant operator is responsible for performing the pressure test.

---



#### **Tip**

*Our after-sales service can support you to plan and perform a pressure test for your plant.*

---

During the pressure test, make sure the following conditions are met:

- Retract the plug stem to open the valve.
- Observe the maximum permissible pressure for both the valve and plant.

## 6 Start-up

The work described in this section is only to be performed by personnel appropriately qualified to carry out such tasks.

### **⚠ WARNING**

**Risk of burn injuries due to hot or cold components and pipeline.**

Valve components and the pipeline may become very hot or cold. Risk of burn injuries.

- Allow components and pipelines to cool down or warm up to the ambient temperature.
- Wear protective clothing and safety gloves.

### **⚠ WARNING**

**Risk of personal injury due to pressurized components and process medium being discharged.**

- Do not loosen the screw of the test connection while the valve is pressurized.

### **⚠ WARNING**

**Risk of hearing loss or deafness due to loud noise.**

Noise emission (e.g. cavitation or flashing) may occur during operation caused by the process medium and the operating conditions. Additionally, a loud noise may briefly occur through the sudden venting of the pneumatic actuator or pneumatic valve accessories not fitted with noise-reducing fittings. Both can damage hearing.

- Wear hearing protection when working near the valve.

### **⚠ WARNING**

**Crush hazard arising from actuator and plug stem moving.**

- Do not insert hands or finger into the yoke while the air supply is connected to the actuator.
- Before working on the control valve, disconnect and lock the pneumatic air supply as well as the control signal.
- Do not impede the movement of the actuator and plug stem by inserting objects into the yoke.
- Before unblocking the actuator and plug stem after they have become blocked (e.g. due to seizing up after remaining in the same position for a long time), release any stored energy in the actuator (e.g. spring compression). See associated actuator documentation.

### **⚠ WARNING**

**Risk of personal injury due to exhaust air being vented.**

While the valve is operating, air is vented from the actuator, for example, during closed-loop operation or when the valve opens or closes.

- Wear eye protection when working in close proximity to the control valve.

## Start-up

Before start-up or putting the valve back into service, make sure the following conditions are met:

- The valve is properly installed into the pipeline (see the 'Installation' section).
- The leak and function tests have been completed successfully (see 'Testing the installed valve' in the 'Installation' section).
- The prevailing conditions in the plant section concerned meet the valve sizing requirements (see information under 'Intended use' in the 'Safety instructions and measures' section).

### **Start-up/putting the valve back into operation**

1. Allow the valve to cool down or warm up to reach ambient temperature before start-up when the ambient temperature and process medium temperature differ greatly or the medium properties require such a measure.
2. Slowly open the shut-off valves in the pipeline. Slowly opening these valves prevents a sudden surge in pressure and high flow velocities which can damage the valve.
3. Check the valve to ensure it functions properly.



## 7 Operation

Immediately after completing start-up or putting the valve back into operation, the valve is ready for use.

### **⚠ WARNING**

**Risk of burn injuries due to hot or cold components and pipeline.**

Valve components and the pipeline may become very hot or cold. Risk of burn injuries.

- Allow components and pipelines to cool down or warm up to the ambient temperature.
- Wear protective clothing and safety gloves.

### **⚠ WARNING**

**Risk of personal injury due to pressurized components and process medium being discharged.**

- Do not loosen the screw of the test connection while the valve is pressurized.

### **⚠ WARNING**

**Risk of hearing loss or deafness due to loud noise.**

Noise emission (e.g. cavitation or flashing) may occur during operation caused by the process medium and the operating conditions. Additionally, a loud noise may briefly occur through the sudden venting of the pneumatic actuator or pneumatic valve accessories not fitted with noise-reducing fittings. Both can damage hearing.

- Wear hearing protection when working near the valve.

### **⚠ WARNING**

**Crush hazard arising from actuator and plug stem moving.**

- Do not insert hands or finger into the yoke while the air supply is connected to the actuator.
- Before working on the control valve, disconnect and lock the pneumatic air supply as well as the control signal.
- Do not impede the movement of the actuator and plug stem by inserting objects into the yoke.
- Before unblocking the actuator and plug stem after they have become blocked (e.g. due to seizing up after remaining in the same position for a long time), release any stored energy in the actuator (e.g. spring compression). See associated actuator documentation.

### **⚠ WARNING**

**Risk of personal injury due to exhaust air being vented.**

While the valve is operating, air is vented from the actuator, for example, during closed-loop operation or when the valve opens or closes.

- Wear eye protection when working in close proximity to the control valve.



## 8 Malfunctions

Read hazard statements, warnings and caution notes in the 'Safety instructions and measures' section.

### 8.1 Troubleshooting

Malfunction	Possible reasons	Recommended action
Actuator and plug stem does not move on demand.	Actuator is blocked.	Check attachment. Remove the blockage. <b>WARNING!</b> A blocked actuator or plug stem (e.g. due to seizing up after remaining in the same position for a long time) can suddenly start to move uncontrollably. Injury to hands or fingers is possible if they are inserted into the actuator or valve. Before trying to unblock the actuator or plug stem, disconnect and lock the pneumatic air supply as well as the control signal. Before unblocking the actuator, release any stored energy in the actuator (e.g. spring compression). See associated actuator documentation.
	Diaphragm in the actuator defective	See associated actuator documentation.
	Signal pressure too low	Check the signal pressure. Check the signal pressure line for leakage.
Jolting movement of the actuator and plug stem	Packing tightened too far	Contact our after-sales service.
Actuator and plug stem does not stroke through the entire range.	Signal pressure too low	Check the signal pressure. Check the signal pressure line for leakage.
	Travel stop active	See associated actuator documentation.
	Incorrect setting of valve accessories	Check the settings of the valve accessories.
Increased flow through closed valve (seat leakage)	Dirt or other foreign particles deposited between the seat and plug.	Shut off the section of the pipeline and flush the valve.
	Valve trim is worn out.	Contact our after-sales service.
Reduced flow rate	Strainer blocked	Clean strainer. See associated device documentation.

## Malfunctions

Malfunction	Possible reasons	Recommended action
The valve leaks to the atmosphere (fugitive emissions).	Defective packing	Contact our after-sales service.
	Defective bellows seal	Contact our after-sales service.
	Flange joint loose or gasket worn out	Check the flange joint. Replace gasket at the flanged joint (see the 'Servicing' section) or contact our after-sales service.

### **i** Note

Contact our after-sales service for malfunctions not listed in the table.

## 8.2 Emergency action

Upon supply air or control signal failure, the valve moves to its fail-safe position (see 'Design and principle of operation' section).

Plant operators are responsible for emergency action to be taken in the plant.

In the event of a valve malfunction:

1. Close the shut-off valves upstream and downstream of the control valve to stop the process medium from flowing through the valve.
2. Perform troubleshooting (see section 8.1).
3. Rectify those malfunctions that can be remedied based on the instructions provided here. Contact our after-sales service in all other cases.

### Putting the valve back into operation after a malfunction

See the 'Start-up' section.

## 9 Servicing

The work described in this section is only to be performed by personnel appropriately qualified to carry out such tasks.

The following documents are also necessary for servicing the valve:

- Mounting and operating instructions for the mounted actuator, e.g. ► EB 8310-X for Type 3271 or Type 3277 Pneumatic Actuator
- ► AB 0100 for tools, tightening torques and lubricant

### **⚠ DANGER**

**Risk of bursting due to incorrect opening of pressurized equipment or components.**

Valves and pipelines are pressure equipment that may burst when handled incorrectly.

Flying projectile fragments or the release of process medium under pressure can cause serious injury or even death.

Before working on the control valve:

- ➔ Depressurize all plant sections affected and the valve (including the actuator). Release any stored energy.
- ➔ Drain the process medium from all the plant sections concerned as well as the valve.

### **⚠ WARNING**

**Risk of burn injuries due to hot or cold components and pipeline.**

Valve components and the pipeline may become very hot or cold. Risk of burn injuries.

- ➔ Allow components and pipelines to cool down or warm up to the ambient temperature.
- ➔ Wear protective clothing and safety gloves.

### **⚠ WARNING**

**Risk of personal injury due to pressurized components and process medium being discharged.**

- ➔ Do not loosen the screw of the test connection while the valve is pressurized.

### **⚠ WARNING**

**Risk of hearing loss or deafness due to loud noise.**

Noise emission (e.g. cavitation or flashing) may occur during operation caused by the process medium and the operating conditions. Additionally, a loud noise may briefly occur through the sudden venting of the pneumatic actuator or pneumatic valve accessories not fitted with noise-reducing fittings. Both can damage hearing.

- ➔ Wear hearing protection when working near the valve.

---

### **⚠ WARNING**

#### **Crush hazard arising from actuator and plug stem moving.**

- Do not insert hands or finger into the yoke while the air supply is connected to the actuator.
  - Before working on the control valve, disconnect and lock the pneumatic air supply as well as the control signal.
  - Do not impede the movement of the actuator and plug stem by inserting objects into the yoke.
  - Before unblocking the actuator and plug stem after they have become blocked (e.g. due to seizing up after remaining in the same position for a long time), release any stored energy in the actuator (e.g. spring compression). See associated actuator documentation.
- 

### **⚠ WARNING**

#### **Risk of personal injury due to exhaust air being vented.**

While the valve is operating, air is vented from the actuator, for example, during closed-loop operation or when the valve opens or closes.

- Wear eye protection when working in close proximity to the control valve.
- 

### **⚠ WARNING**

#### **Risk of personal injury due to preloaded springs.**

Actuators with preloaded springs are under tension. They can be identified by the long

bolts protruding from the bottom of the actuator.

- Before starting any work on the actuator, relieve the compression from the preloaded springs (see associated actuator documentation).
- 

### **⚠ WARNING**

#### **Risk of personal injury due to residual process medium in the valve.**

While working on the valve, residual medium can flow out of the valve and, depending on its properties, cause personal injury, e.g. (chemical) burns.

- Wear protective clothing, safety gloves and eye protection.
- 

### **ⓘ NOTICE**

#### **Risk of valve damage due to excessively high or low tightening torques.**

Observe the specified torques when tightening control valve components. Excessive tightening torques lead to parts wearing out more quickly. Parts that are too loose may cause leakage.

- Observe the specified tightening torques (▶ AB 0100).
- 

### **ⓘ NOTICE**

#### **Risk of valve damage due to the use of unsuitable tools.**

- Only use tools approved by SAMSON (▶ AB 0100).
-

**NOTICE**

**Risk of valve damage due to the use of unsuitable lubricants.**

→ Only use lubricants approved by SAMSON (▶ AB 0100).

– Only use original spare parts by SAMSON, which comply with the original specifications.

**Note**

The control valve was checked by SAMSON before it left the factory.

– Certain test results certified by SAMSON lose their validity when the valve is opened. Such testing includes seat leakage and leak tests.

– After completing servicing work, the gas-tight shut-off of the valve must be tested. This test must be performed by fully trained, qualified operating personnel.

– The product warranty becomes void if service or repair work not described in these instructions is performed without prior agreement by SAMSON's After-sales Service.

## 9.1 Periodic testing

Depending on the operating conditions, check the valve at certain intervals to prevent a possible failure before it can occur. Plant operators are responsible for drawing up an inspection and test plan.

**Tip**

Our after-sales service can support you in drawing up an inspection and test plan for your plant.

We recommend the following inspection and testing which can be performed while the process is running:

Inspection and testing	Action to be taken in the event of a negative result:
Check the markings, labels and nameplates on the valve for their readability and completeness.	Immediately renew damaged, missing or incorrect nameplates or labels.
	Clean any inscriptions that are covered with dirt and are illegible.

## Servicing

Inspection and testing	Action to be taken in the event of a negative result:
<p>Check the pipe connections and gaskets on the valve and actuator for leakage.</p>	<p>Check the bolted joint (tightening torque).</p>
	<p>Put the control valve out of operation (see the 'Decommissioning' section). Replace the gasket on the flanged joint as described in section 9.4.</p>
	<p>If the valve continues to leak, put the control valve out of operation (see the 'Decommissioning' section) and contact our after-sales service.</p>
<p>Check the test connection and bellows seal (if used) for external leakage. <b>WARNING!</b> Risk of personal injury due to pressurized components and process medium being discharged. Do not loosen the screw of the test connection while the valve is pressurized.</p>	<p>Put the control valve out of operation (see the 'Decommissioning' section). To repair the bellows seal, contact our after-sales service (see the 'Repairs' section).</p>
<p>Check the valve's seat leakage.</p>	<p>Shut off the section of the pipeline and flush the valve to remove any dirt and/or deposited foreign particles between the seat and plug.</p>
	<p>Put the control valve out of operation (see the 'Decommissioning' section) and contact our after-sales service.</p>
<p>Check the valve for external damage (e.g. corrosion).</p>	<p>Remove any damage immediately. If necessary, put the control valve out of operation (see the 'Decommissioning' section).</p>
<p>Check the valve accessories to ensure they are mounted properly.</p>	<p>Tighten the connections of the valve accessories.</p>
<p>Check to ensure that the actuator and plug stem move smoothly.</p>	<p>Contact our after-sales service.</p>
	<p>Unblock a blocked actuator and plug stem. <b>WARNING!</b> A blocked actuator or plug stem (e.g. due to seizing up after remaining in the same position for a long time) can suddenly start to move uncontrollably. Injury to hands or fingers is possible if they are inserted into the actuator or valve. Before trying to unblock the actuator or plug stem, disconnect and lock the pneumatic air supply as well as the control signal. Before unblocking the actuator, release any stored energy in the actuator (e.g. spring compression). See associated actuator documentation.</p>
<p>If possible, check the valve's fail-safe position by briefly interrupting the air supply.</p>	<p>Put the control valve out of operation (see the 'Decommissioning' section). Identify the cause for the malfunction and rectify it (see the 'Troubleshooting' section).</p>



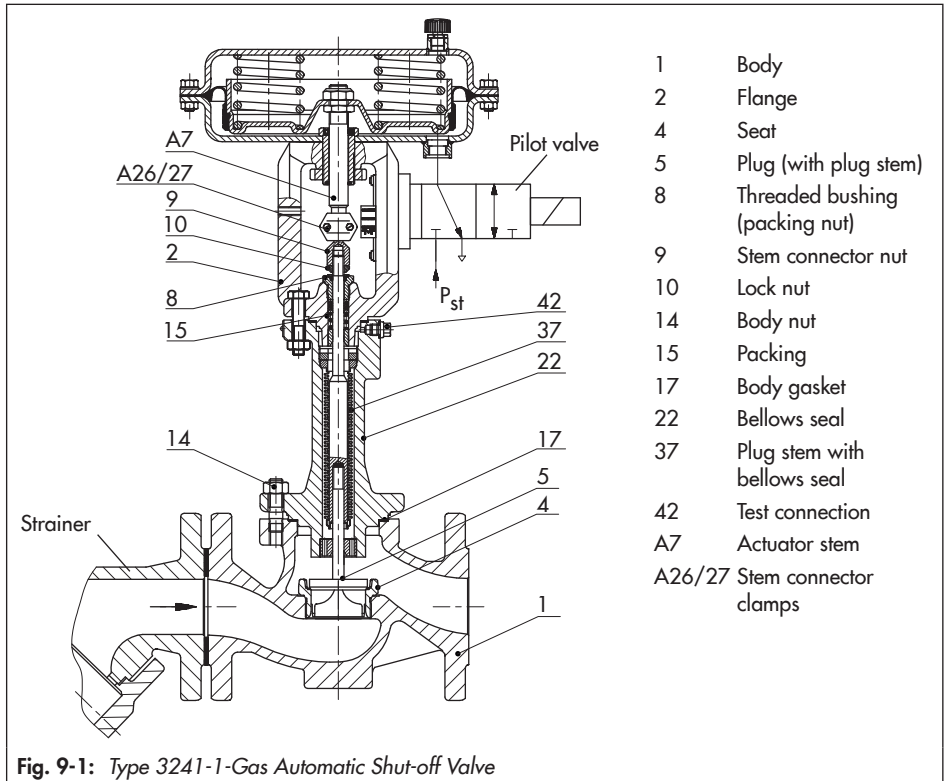

### 9.2 Preparing the valve for service work

1. Lay out the necessary material and tools to have them ready for the service work.
2. Put the control valve out of operation (see the 'Decommissioning' section).
3. Remove the actuator from the valve. See associated actuator documentation.
3. Test the valve (see Table 9-1). The tests must be documented.
4. Put the control valve back into operation (see the 'Start-up' section). Observe the requirements and conditions for start-up or putting the valve back into operation.

---

#### Note

*To remove an actuator with "stem extends" fail-safe action and/or with preloaded springs, a certain signal pressure must be applied to the actuator (see associated actuator documentation). Afterwards, the signal pressure must be removed and the air supply disconnected again and locked.*

---

---

#### Tip

*We recommend removing the valve from the pipeline before performing any service work (see information under 'Removing the valve from the pipeline' in the 'Removal' section).*

---

The following service work can be performed after preparation is completed:

- Replace the gasket (see section 9.4.1)

### 9.3 Completing service work

1. Mount actuator. See associated actuator documentation.
2. Adjust lower or upper signal bench range. See associated actuator documentation.

**Table 9-1: Required tests**

<b>Seat leakage testing</b>	
Standard	IEC 60534-4 or ANSI/FCI 70-2
Test medium	Use dry compressed air free of oil and grease
Test pressure	Inlet: 4 bar (standard); max. 40 bar Outlet: atmospheric pressure or connection to a flow meter
Test procedure	<ol style="list-style-type: none"> <li>1. Move the plug out of the seat (valve closed).</li> <li>2. Apply the test medium at the test pressure to the inlet side.</li> <li>3. As soon as the leakage rate is constant, measure the seat leakage. Make sure the measured seat leakage does not exceed the maximum permissible leakage rate specified for the associated leakage class.</li> </ol>
<b>Leak test</b>	
Standard	Test similar to DIN EN 12266-1, test P11
Test medium	Use dry compressed air free of oil and grease
Test pressure	5 bar (standard)
Test time	See DIN EN 12266-1
Test procedure	<ol style="list-style-type: none"> <li>1. Clamp the valve into the test fixture or fit it with a test adapter.</li> <li>2. Move the plug out of the seat (valve open).</li> <li>3. Apply the test pressure to the valve and hold the pressure for the specified test duration.</li> <li>4. Perform the leak test visually using leak detection spray or immerse the valve in a water bath. No bubbles must become visible during the test period.</li> <li>5. Leak-test the bellows. For example, connect a hose to the test connection and immerse the end of the hose into a water bath. No bubbles must become visible during the test period.</li> <li>6. After the test duration has elapsed, reduce the test pressure to atmospheric pressure.</li> </ol>
<b>Function test: testing the rated travel</b>	
Measures for preparation	<p>The actuator is mounted properly.                      Valve accessories (positioner, solenoid valve etc.) are mounted properly.                      The packing is tightened correctly.                      No pressure prevails inside the valve.</p>
Test procedure	<ol style="list-style-type: none"> <li>1. Apply the input signal to move the valve to the end positions.</li> <li>2. Determine the rated travel using the travel indicator scale.</li> </ol>

## 9.4 Service work

- ➔ Before performing any service work, preparations must be made to the control valve (see section 9.2).
- ➔ Complete all service work as described in section 9.3 and check the control valve before putting it back into operation (see 'Testing the installed valve' in the 'Installation' section).

### 9.4.1 Replacing the gasket

1. Undo the body nuts (14) gradually in a crisscross pattern.
2. Lift the bellows seal (22) with valve bonnet (2) and plug with plug stem (5) off the body (1).
3. Remove the gasket (17). Carefully clean the sealing faces in the valve body (1) and on the bellows seal (22).
4. Insert a new gasket (17) into the body.
5. Place the bellows seal (22) with valve bonnet (2) and plug with plug stem (5) onto the body.

**Version with V-port plug:** place the assembly onto the valve body, making sure that the largest V-shaped port of the V-port plug faces toward the valve outlet. See information under 'Aligning the V-port plug'.

6. Firmly press the plug (5) into the seat (4). Fasten down the bellows seal (22) with the body nuts (14). Tighten the nuts gradually in a crisscross pattern. Observe tightening torques.

### Aligning the V-port plug

To achieve the best flow conditions inside the valve, the V-port plug must always be installed with the port that releases the flow first when the valve opens facing toward the valve outlet. This is the largest of the three V-shaped ports (see Fig. 9-2).

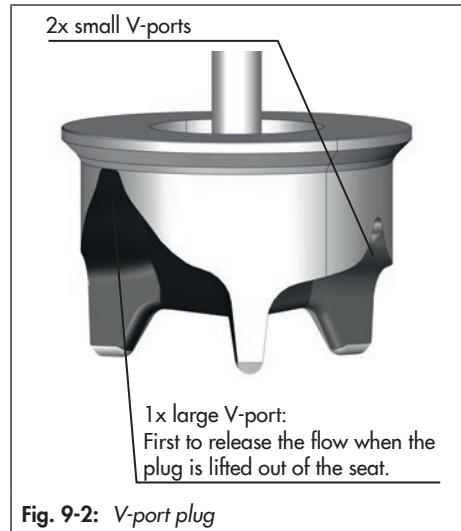

Fig. 9-2: V-port plug

### 9.4.2 Cleaning the strainer

See associated device documentation.

## 9.5 Ordering spare parts and operating supplies

Contact your nearest SAMSON subsidiary or SAMSON's After-sales Service for information on spare parts, lubricants and tools.

### **Spare parts**

See Annex for details on spare parts.

### **Lubricant**

See document ► AB 0100 for details on suitable lubricants.

### **Tools**

See document ► AB 0100 for details on suitable tools.



## 10 Decommissioning

The work described in this section is only to be performed by personnel appropriately qualified to carry out such tasks.

### **⚠ DANGER**

**Risk of bursting due to incorrect opening of pressurized equipment or components.**

Valves and pipelines are pressure equipment that may burst when handled incorrectly.

Flying projectile fragments or the release of process medium under pressure can cause serious injury or even death.

Before working on the control valve:

- Depressurize all plant sections affected and the valve (including the actuator). Release any stored energy.
- Drain the process medium from all the plant sections concerned as well as the valve.

### **⚠ WARNING**

**Risk of burn injuries due to hot or cold components and pipeline.**

Valve components and the pipeline may become very hot or cold. Risk of burn injuries.

- Allow components and pipelines to cool down or warm up to the ambient temperature.
- Wear protective clothing and safety gloves.

### **⚠ WARNING**

**Risk of personal injury due to pressurized components and process medium being discharged.**

- Do not loosen the screw of the test connection while the valve is pressurized.

### **⚠ WARNING**

**Risk of hearing loss or deafness due to loud noise.**

Noise emission (e.g. cavitation or flashing) may occur during operation caused by the process medium and the operating conditions. Additionally, a loud noise may briefly occur through the sudden venting of the pneumatic actuator or pneumatic valve accessories not fitted with noise-reducing fittings. Both can damage hearing.

- Wear hearing protection when working near the valve.

### **⚠ WARNING**

**Crush hazard arising from actuator and plug stem moving.**

- Do not insert hands or finger into the yoke while the air supply is connected to the actuator.
- Before working on the control valve, disconnect and lock the pneumatic air supply as well as the control signal.
- Do not impede the movement of the actuator and plug stem by inserting objects into the yoke.
- Before unblocking the actuator and plug stem after they have become blocked

## Decommissioning

(e.g. due to seizing up after remaining in the same position for a long time), release any stored energy in the actuator (e.g. spring compression). See associated actuator documentation.

---

### **WARNING**

#### **Risk of personal injury due to exhaust air being vented.**

While the valve is operating, air is vented from the actuator, for example, during closed-loop operation or when the valve opens or closes.

→ Wear eye protection when working in close proximity to the control valve.

---

### **WARNING**

#### **Risk of personal injury due to residual process medium in the valve.**

While working on the valve, residual medium can flow out of the valve and, depending on its properties, cause personal injury, e.g. (chemical) burns.

→ Wear protective clothing, safety gloves and eye protection.

---

To decommission the control valve for service work or to remove it from the pipeline, proceed as follows:

1. Close the shut-off valves upstream and downstream of the control valve to stop the process medium from flowing through the valve.
2. Completely drain the pipelines and valve.

3. Disconnect and lock the pneumatic air supply to depressurize the actuator.
4. Release any stored energy.
5. If necessary, allow the pipeline and valve components to cool down or warm up to the ambient temperature.



## 11 Removal

The work described in this section is only to be performed by personnel appropriately qualified to carry out such tasks.

### **⚠ WARNING**

#### **Risk of burn injuries due to hot or cold components and pipeline.**

Valve components and the pipeline may become very hot or cold. Risk of burn injuries.

- Allow components and pipelines to cool down or warm up to the ambient temperature.
- Wear protective clothing and safety gloves.

### **⚠ WARNING**

#### **Crush hazard arising from actuator and plug stem moving.**

- Do not insert hands or finger into the yoke while the air supply is connected to the actuator.
- Before working on the control valve, disconnect and lock the pneumatic air supply as well as the control signal.
- Do not impede the movement of the actuator and plug stem by inserting objects into the yoke.
- Before unblocking the actuator and plug stem after they have become blocked (e.g. due to seizing up after remaining in the same position for a long time), release any stored energy in the actuator (e.g. spring compression). See associated actuator documentation.

### **⚠ WARNING**

#### **Risk of personal injury due to residual process medium in the valve.**

While working on the valve, residual medium can flow out of the valve and, depending on its properties, cause personal injury, e.g. (chemical) burns.

- Wear protective clothing, safety gloves and eye protection.

### **⚠ WARNING**

#### **Risk of personal injury due to preloaded springs.**

Actuators with preloaded springs are under tension. They can be identified by the long bolts protruding from the bottom of the actuator.

- Before starting any work on the actuator, relieve the compression from the preloaded springs.

Before removing the valve, make sure the following conditions are met:

- The control valve is put out of operation (see the 'Decommissioning' section).

### 11.1 Removing the valve from the pipeline

1. Support the valve to hold it in place when separated from the pipeline (see the 'Shipment and on-site transport' section).
2. Unbolt the flange joint.

## Removal

3. Remove the valve from the pipeline (see the 'Shipment and on-site transport' section).

### **11.2 Removing the actuator from the valve**

See associated actuator documentation.

## 12 Repairs

If the valve does not function properly according to how it was originally sized or does not function at all, it is defective and must be repaired or exchanged.

### ! NOTICE

**Risk of valve damage due to incorrect service or repair work.**

- ➔ Do not perform any repair work on your own.
- ➔ Contact SAMSON's After-sales Service for repair work.

### 12.1 Returning devices to SAMSON

Defective devices can be returned to SAMSON for repair.

Proceed as follows to return devices:

1. Exceptions apply concerning some special device models
  - ▶ [www.samsongroup.com](http://www.samsongroup.com) > Service & Support > After-sales Service.
2. Send an e-mail
  - ▶ [retouren@samsongroup.com](mailto:retouren@samsongroup.com) to register the return shipment including the following information:
    - Type
    - Article no.
    - Configuration ID
    - Original order

- Completed Declaration on Contamination, which can be downloaded from our website at
  - ▶ [www.samsongroup.com](http://www.samsongroup.com) > Service & Support > After-sales Service.

**After checking your registration, we will send you a return merchandise authorization (RMA).**

3. Attach the RMA (together with the Declaration on Decontamination) to the outside of your shipment so that the documents are clearly visible.
4. Send the shipment to the address given on the RMA.

### i Note

*Further information on returned devices and how they are handled can be found at*

- ▶ [www.samsongroup.com](http://www.samsongroup.com) > Service & Support > After-sales Service.



## 13 Disposal

- Observe local, national and international refuse regulations.
- Do not dispose of components, lubricants and hazardous substances together with your household waste.



## 14 Certificates

These declarations are included on the next pages:

- Declaration of conformity in compliance with Pressure Equipment Directive 2014/68/EU on page 14-2
- Declaration of conformity in compliance with Gas Appliances Regulation (EU) 2016/426 on page 14-3
- EC type examination certificate on page 14-4 to 14-5

The certificates shown were up to date at the time of publishing. The latest certificates can be found on our website:

▶ [www.samsongroup.com](http://www.samsongroup.com) > *Products & Applications* > *Product selector* > *Valves* > *3241G*

Other optional certificates are available on request.

EU DECLARATION OF CONFORMITY  
TRANSLATION



**Module D / N° CE-0062-PED-D-SAM 001-20-DEU**

For the following products, SAMSON hereby declares under its sole responsibility:

Devices	Series	Type	Version
Control valve for hot water and steam with fail-safe action	3374 (2000 N)		with Type 2811, 2814, 2823, 3321, 3241 Certificate no.: 01 202 931-B-15-0030
Safety shut-off device for combustion plants	240	3241	with Type 3241-4362 Certificate no.: 01 202 931-B-11-0018
	240	3241	with Type 3241-4364 Certificate no.: 01 202 931-B-11-0019
Control valve for hot water and steam with fail-safe action	240	3241	with Type 3271 Certificate no.: 01 202 931-B-10-0006
	240	3241	with Type 3271 and Type 3277 Certificate no.: 01 202 931-B-10-0009
	3274 (1600 N)		with Type 3241, 2423, 2623 Certificate no.: 01 202 931-B-10-0027
	3274 (3000 N)		with Type 3241, 3214, 2614 Certificate no.: 01 202 931-B-10-0028
Control valve for water and steam with fail-safe action	5725, 5625 (2770)		with Type 3214 (2814), 2423 (2823), 3213 (2710), 3222 (2710), 2488 (2730), 2489 (2750) Certificate no.: 01 202 641-B-19 0017
Safety shut-off device for gas burners and gas equipment	240	3241	with Type 3241-0261 to 3241-0275 Certificate no.: 01 202 931-B-02-0017-01
Control valve for leakage gas discharge for gas burners and gas equipment	240	3241	with Type 3241-4321 Certificate no.: 01 202 931-B-02-0018-01

that the products mentioned above comply with the requirements of the following standards:

Directive of the European Parliament and of the Council on the harmonization of the laws of the Member States relating to the making available on the market of pressure equipment	2014/68/EU	of 15 May 2014
Applied conformity assessment procedure for fluids according to Article 4(1)	Module D	by Bureau Veritas 0062

The manufacturer's quality management system is monitored by the following notified body:  
Bureau Veritas Services SAS, 8 Cours du Triangle, 92800 PUTEAUX – LA DEFENSE

Technical standards applied: DIN EN 12516-2, DIN EN 12516-3, ASME B16.34

Manufacturer: **SAMSON AG, Weismüllerstraße 3, 60314 Frankfurt am Main, Germany**

Frankfurt am Main, 15 May 2020

Dr. Andreas Widl  
Chief Executive Officer (CEO)

Dr. Thomas Steckenreiter  
Chief Technology Officer (CTO)

Revision 07

Classification: Public · SAMSON AKTIENGESELLSCHAFT · Weismüllerstraße 3 · 60314 Frankfurt am Main, Germany

Page 1 of 1



# EU-KONFORMITÄTSERKLÄRUNG

ORIGINAL



SAMSON erklärt in alleiniger Verantwortung für folgende Produkte:

**Stellventil** Typ 3241-1-Gas (mit pneumatischem Antrieb Typ 3271)  
**Stellventil** Typ 3241-7-Gas (mit pneumatischem Antrieb Typ 3277)

die Konformität mit nachfolgender Anforderung:

Verordnung des Europäischen Parlaments und des Rates über Geräte zur Verbrennung gasförmiger Brennstoffe und zur Aufhebung der Richtlinie 2009/142/EG	(EU) 2016/426	vom 9. März 2016
---	------------------	---------------------

**Produktart** Ausrüstungsteile für Gas- und Druckgeräte  
Absperrentil, automatisch, Klasse D

**Produktbezeichnung** 2/2 Wegeventil mit pneumatischem Antrieb,  
spannungslos durch Federkraft geschlossen

**Prüfgrundlagen** (EU) 2016/426  
EN 16678  
DIN 3394-1  
DIN EN 161  
DIN EN 13611  
EG-Richtlinie 2009/142/EG

**Prüfberichte** EU-Baumusterprüfbescheinigung CE-0085CQ0516 vom 11.06.2018  
DVGW CERT GmbH

**Hersteller** SAMSON AG  
Weismüllerstraße 3  
60314 Frankfurt am Main, Germany

Frankfurt am Main, 06.07.2018

Klaus Hörschken  
Zentralabteilungsleiter  
Entwicklung Ventile und Antriebe

Dr. Michael Heß  
Zentralabteilungsleiter  
Product Management & Technical Sales

## EU type examination certificate

### EU-Baumusterprüfbescheinigung

CE-0085CQ0516

Product Identification No.  
Produkt-Identnummer

<b>Field of Application</b> <i>Anwendungsbereich</i>	EU Gas Appliances Regulation (EU/2016/426) <i>EU-Gasgeräteverordnung (EU/2016/426)</i>
<b>Owner of Certificate</b> <i>Zertifikatinhaber</i>	Samson AG Weismüllerstraße 3, D-60314 Frankfurt am Main
<b>Distributor</b> <i>Vertreiber</i>	Samson AG Weismüllerstraße 3, D-60314 Frankfurt am Main
<b>Product Category</b> <i>Produktart</i>	accessories for gas appliances/pressure equipment: Automatic shut-off valve (4128)
<b>Product Description</b> <i>Produktbezeichnung</i>	2/2 way-valve with pneumatic actuator, current-free closed
<b>Model</b> <i>Modell</i>	3241G
<b>Countries of Destination</b> <i>Bestimmungsländer</i>	AT, BE, BG, CH, CY, CZ, DE, DK, EE, ES, FI, FR, GB, GR, HR, HU, IE, IS, IT, LT, LU, LV, MT, NL, NO, PL, PT, RO, SE, SI, SK
<b>Test Reports</b> <i>Prüfberichte</i>	type testing: V-A 1560-01/18 from 10.01.2018 (TSG)
<b>Test Basis</b> <i>Prüfgrundlagen</i>	EU/2016/426 A III B (09.03.2016) DIN EN 16678 (01.02.2016) DIN EN 161 (01.04.2013)- partially DIN EN 13611 (01.12.2011)

10029 04 01 02

**Date of Expiry / File No.** 26.02.2028 / 17-0750-GEA  
**Ablaufdatum / AZ**

11.06.2018 Rie A-1/2

Date, Issued by, Sheet, Head of Certification Body  
Datum, Bearbeiter, Blatt, Leiter der Zertifizierungsstelle

DVGW CERT GmbH is an accredited body by DAkkS according to DIN EN ISO/IEC 17065:2013 and notified by the government of the Federal Republic of Germany for certification of gas appliances under EU Regulation

DVGW CERT GmbH ist von der DAkkS nach DIN EN ISO/IEC 17065:2013 akkreditierte und von der Deutschen Bundesregierung benannte Stelle für die Zertifizierung von Gasgeräten gemäß EU-Verordnung EU/2016/426.



Deutsche  
Akkreditierungsstelle  
D-ZE-16028-01-01

DVGW CERT GmbH  
Zertifizierungsstelle

Josef-Wirmer-Str. 1-3  
53123 Bonn

Tel. +49 228 91 88 - 888

Fax +49 228 91 88 - 993

www.dvgw-cert.com  
info@dvgw-cert.com

Gas Category <i>Gasart</i>	Remarks <i>Bemerkungen</i>
fuel gases of the 1., 2. & 3. gas family	

Type <i>Typ</i>	Technical Data <i>Technische Daten</i>	Remarks <i>Bemerkungen</i>
3241-1-Gas; 3241-7-Gas	nominal diameter: DN 15	
3241-1-Gas; 3241-7-Gas	nominal diameter: DN 25	
3241-1-Gas; 3241-7-Gas	nominal diameter: DN 40	
3241-1-Gas; 3241-7-Gas	nominal diameter: DN 50	
3241-1-Gas; 3241-7-Gas	nominal diameter: DN 80	
3241-1-Gas; 3241-7-Gas	nominal diameter: DN 100	
3241-1-Gas; 3241-7-Gas	nominal diameter: DN 150	

Type Variation <i>Ausführungsvariante</i>	Explanations <i>Erläuterungen</i>
3241-1-Gas	with actuator type 3271
3241-7-Gas	with actuator type 3277

#### Hints of Utilization /Remarks

##### *Verwendungshinweise / Bemerkungen*

connection: flange connection according to DIN 2501 or ISO 7005 and optionally ANSI class 300

ambient temperature range: -40...+60 ° C

class: D

max. operating pressure: 20 bar (seat diameter <= 48 mm), 15 bar (seat diameter 63 mm and 80 mm), 10 bar (seat diameter 100 mm), 5 bar (seat diameter 130 mm)



## 15 Annex

### 15.1 Tightening torques, lubricants and tools

► AB 0100 for tools, tightening torques and lubricants

### 15.2 Spare parts

1	Body (valve)
2	Flange
4	Seat
5	Plug (with plug stem)
7	Guide bushing (flange)
8	Threaded bushing (packing nut)
9	Stem connector nut
10	Lock nut
11	Spring
12	Washer
13	Stud bolt
14	Body nut
15	Packing
16	V-ring packing
17	Body gasket
19	Bushing
22	Bellows seal
24	Guide bushing
27	Flange
28	Clamping ring
29	Plug for version with bellows seal
30	Retaining washers
31	Washer
32	Bolt
33	Nut
34	Screw

### 15.2 Spare parts

37	Plug stem with metal bellows
39	Gasket
41	Nut
42	Screw plug with seal
80	Valve nameplate
81	Grooved pin
82	Screw
83	Hanger
84	Travel indicator scale
91	Protective cap
210	Nameplate for gas version
212	Plate with DVGW register number
S1	Body (strainer)
A1	Top diaphragm case
A2	Bottom diaphragm case
A4	Diaphragm
A5	Diaphragm plate
A6	Hose clamp
A7	Actuator stem
A8	Ring nut
A9	Hex nut
A10/	Spring
11/12	
A15	Collar nut
A16	Vent plug
A20	Hex bolt
A21	Hex nut
A22	Hex bolt (preloading)
A23	Hex nut (preloading)
A24	Blanking plug
A25	Washer
A26/27	Stem connector clamp
A28	Bracket
A29	Hex bolt
A30	Hex nut

## 15.2 Spare parts

A32	Hanger
A40	Radial shaft seal
A41	Wiper ring
A42	Dry bearing
A43	Hex bolt
A100	Nameplate
A106	Grooved pin

---

**i Note**

*The exploded diagram shows a Type 3241G with a Type 3271 Pneumatic Actuator with 350 cm<sup>2</sup> actuator area. Contact our after-sales service for other exploded diagrams.*

---

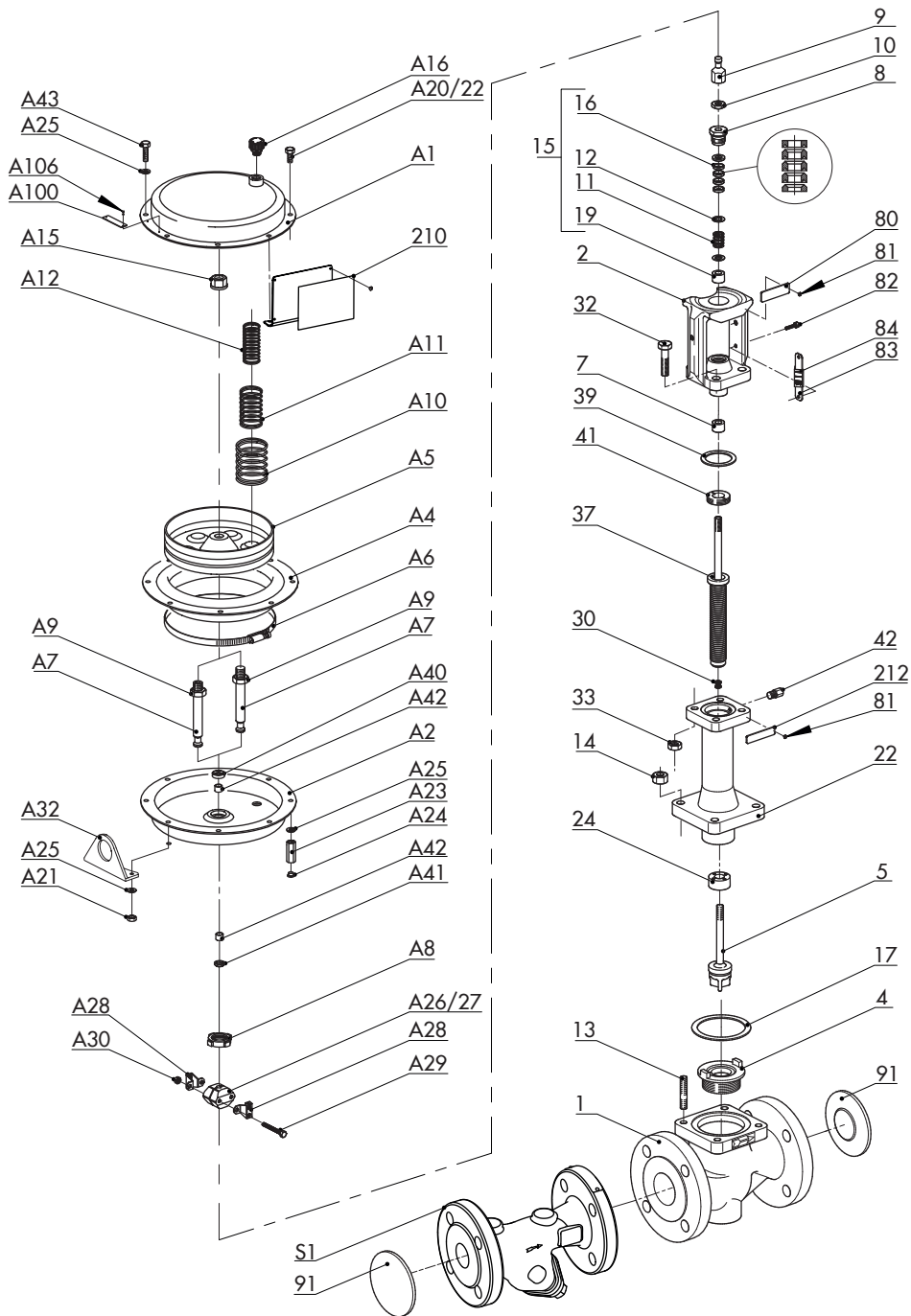

### 15.3 After-sales service

Contact our after-sales service for support concerning service or repair work or when malfunctions or defects arise.

#### E-mail address

You can reach our after-sales service at [aftersalesservice@samsongroup.com](mailto:aftersalesservice@samsongroup.com).

#### Addresses of SAMSON AG and its subsidiaries

The addresses of SAMSON AG, its subsidiaries, representatives and service facilities worldwide can be found on our website ([www.samsongroup.com](http://www.samsongroup.com)) or in all SAMSON product catalogs.

#### Required specifications

Please submit the following details:

- Order number and position number in the order
- Type, model number, valve size and valve version
- Pressure and temperature of the process medium
- Flow rate in kg/h or Nm<sup>3</sup>/h
- Bench range of the actuator (e.g. 0.2 to 1 bar)
- Installation drawing









**EB 8020 EN**



SAMSON AKTIENGESELLSCHAFT  
Weismüllerstraße 3 · 60314 Frankfurt am Main, Germany  
Phone: +49 69 4009-0 · Fax: +49 69 4009-1507  
samson@samsongroup.com · www.samsongroup.com