



SAMSON



SOLUTIONS

Intelligent Valve Engineering
from a Single Source

SMART IN FLOW CONTROL

SAMSON – For over one hundred years, SAMSON has developed and manufactured control equipment for industrial processes. From rugged self-operated regulators to highly specialized process control valves, we manufacture devices in all common sizes, in standard materials and exotic alloys, equipped with different actuators, tailor made for the specific demands of each application. In addition, we supply turnkey systems.

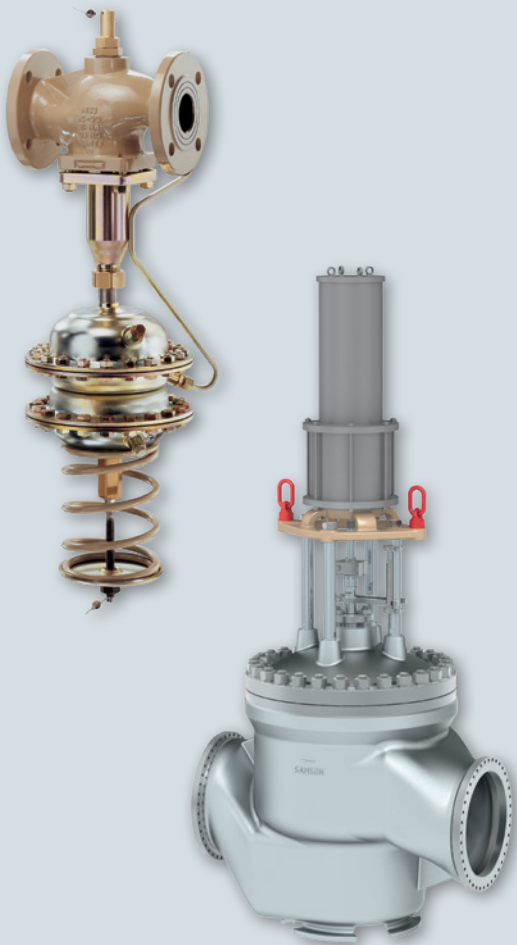

SAMSON AIR TORQUE – Manufacturing pneumatic rotary actuators for any kind of rotary control valve, AIR TORQUE has become the world leader in this special field. Technical features of the actuators include external adjustment of the end positions and their involute gearing, which continuously converts the travel movement into a rotary motion without any friction.

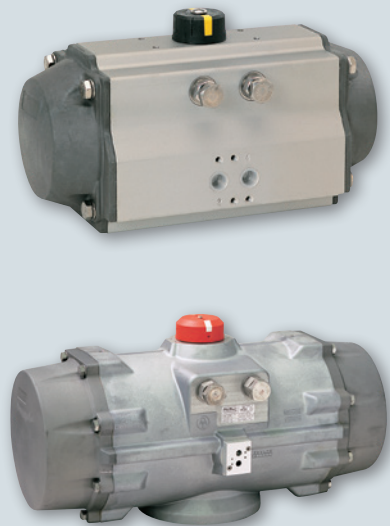

SAMSON CERA SYSTEM – High-performance ceramic materials provide solutions wherever standard valves reach their limits in resistance to wear, corrosion and high temperatures. CERA SYSTEM specializes in ball and sliding disk valves as well as pipe components with ceramic linings. Industry-specific applications catered for include coal gasification and photovoltaics.

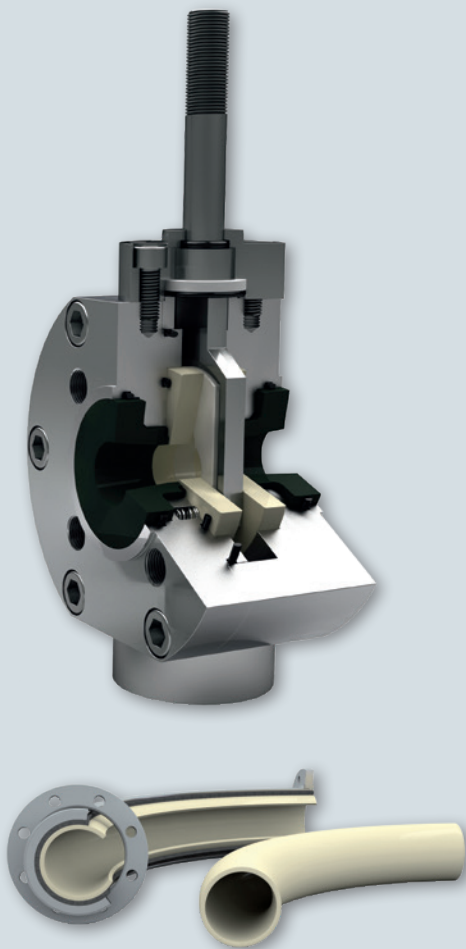

SAMSON LEUSCH – The specialized manufacturer focuses on valves for pipe diameters up to three meters. LEUSCH's control and shut-off butterfly valves, ball valves and segmented ball valves are equipped with soft or metal seals, are suitable for both extremely low and extremely high temperatures from -196 to $+1000$ °C and can handle high pressure ratings up to PN 420 or Class 2500.

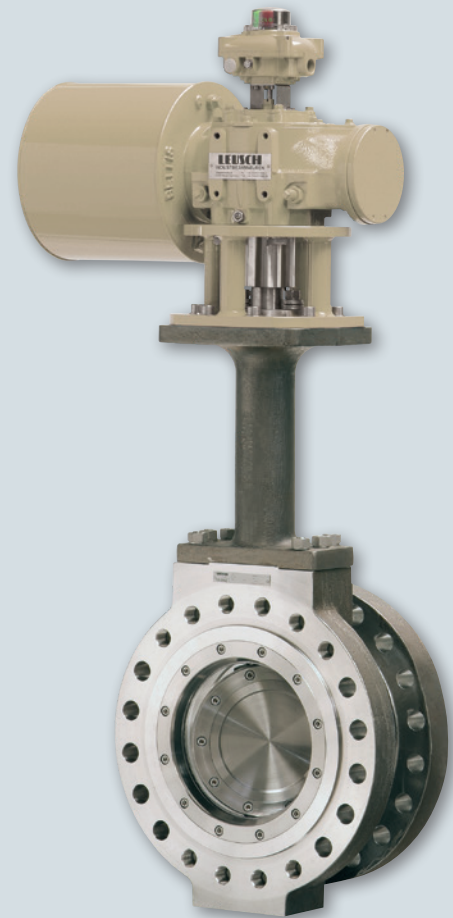

SAMSON PFEIFFER – The high-quality, homogeneous polymer linings, such as PTFE and PFA, are used in control, butterfly and ball valves to provide solutions for numerous applications. A wide product range of ball and butterfly valves made of metal alloys, turnkey pigging systems, pigging components and sampling valve technology round off the product portfolio.

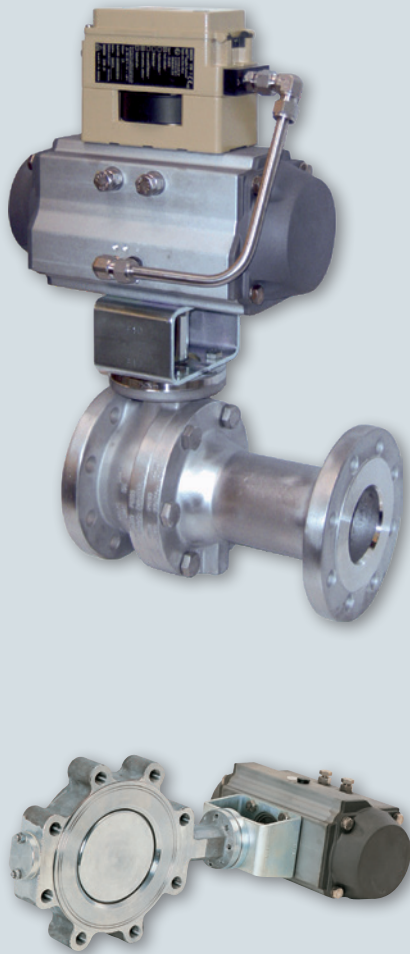

SAMSON RINGO VÁLVULAS – The valve specialist is renowned for valves in large nominal sizes and high pressure ratings for power stations as well as the oil and gas sector. Its product range includes ball valves, control valves, gate, globe and check valves, choke valves and axial flow valves as well as special valves, such as subsea valves or double block-and-bleed valves.

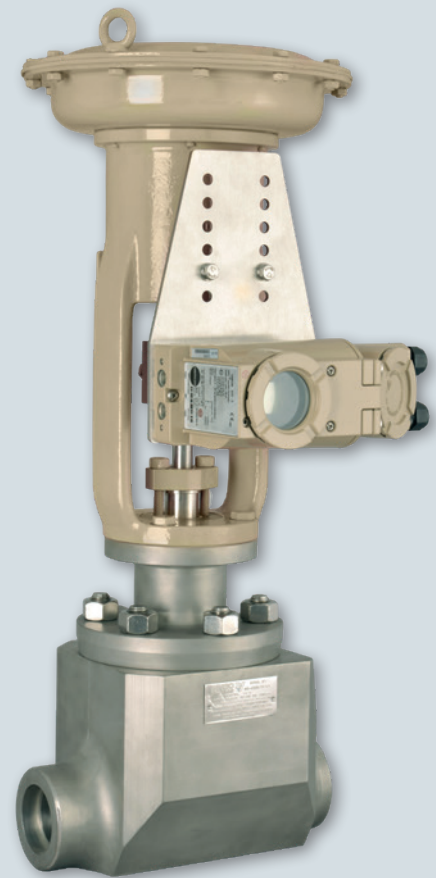

SAMSON SED – SED specializes in the development, manufacture and distribution of diaphragm valves, seat valves and variable area flow meters. In addition, SED offers a wide range of mechanical and electric accessories for monitoring and control that is perfectly tailored to the valves. Valve bodies and actuator components are made of high-quality metals and plastic materials.



SAMSON STARLINE – Forged steel ball valves in sizes NPS ¼ to 12 and ANSI Class 150 to 2500 as well as in API 6A pressure ratings are mainly used in special applications, such as upstream, cryogenic and high-temperature service. Thanks to superior quality, STARLINE is a top supplier to all major oil and gas companies as well as EPC contractors.

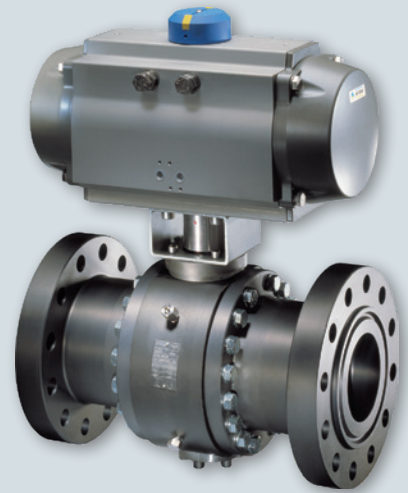

SAMSON VETEC – VETEC's Maxifluss valves combine the advantages of conventional control valves, butterfly valves and ball valves. Their universal design allows them to be used in standard and critical applications. Thanks to the eccentric design of the rotary plug, it only comes into contact with the valve seat when the valve is completely closed. This means that the valves can control at high rangeability.

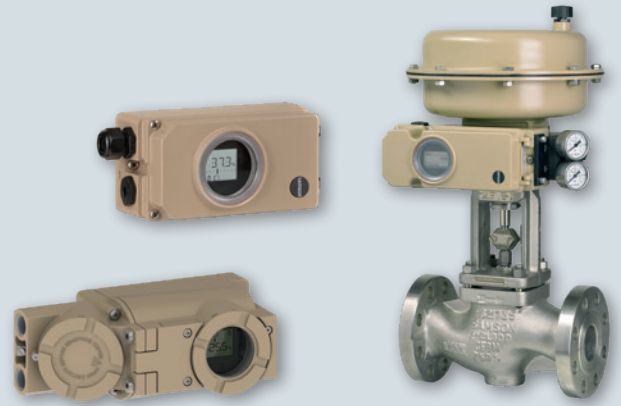
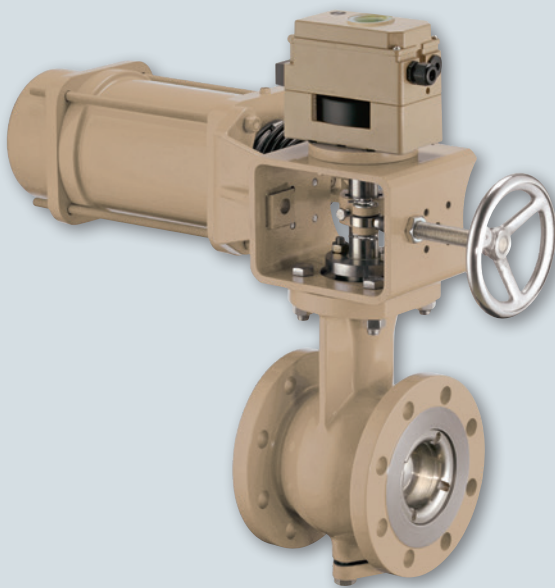

SAMSON develops and manufactures control valves to meet all requirements, from forged ball valves to bypass valves installed in steam turbines. We offer the full range of high-quality and state-of-the-art control equipment for industrial processes.

Engineered solutions from a single source, for example valves fitted with accessories, are also part of our product portfolio.

Control valves automated with SAMSON positioners communicate using all common protocols and bus systems and can be integrated seamlessly into all common process control systems.

The benefit for you is clear: SAMSON provides you with valve engineering and customer service from one single source.



At SAMSON, the staff's know-how on valves, actuators and positioners as well as the customers' knowledge of their processes are brought together. Based on this large pool of knowledge and over 100 years of experience in valve engineering, SAMSON has added digital applications to the product range. The SAM DIGITAL line creates a true added value by providing targeted data analyses.

- A new level of transparency is achieved with the cloud-based business applications in SAM DIGITAL: for critical individual assets as well as for a large number of devices. You have flexibility in integrating functions from other business applications into your preferred application with SAM DIGITAL's modular design. Our objective is to transform the data available in your specific process environment into valuable and actionable information.

The following industry-specific applications are already available:

- SAM VALVE MANAGEMENT: business application for smart valve diagnostics
- SAM TANK MANAGEMENT: business application for smart filling level monitoring
- SAM DISTRICT ENERGY: business application specially for district heating and cooling
- SAM GUARD analyzes the collected data based on machine learning and big-data analyses. The system monitors the entire plant and recognizes cause-and-effect relations between the components so that alerts are generated early on. SAM GUARD focuses on only a few truly actionable alerts per day and spotlights plant components to help prevent unexpected plant downtime and failures.

SAM[®]
DIGITAL

SAMSON AT A GLANCE



STAFF

- Worldwide 4,500
- Europe 3,600
- Asia 700
- Americas 200
- Frankfurt am Main, Germany 1,800

INDUSTRIES AND APPLICATIONS

- Chemicals and petrochemicals
- Food and beverages
- Pharmaceuticals and biotechnology
- Oil and gas
- Liquefied Natural Gas (LNG)
- Marine equipment
- Power and energy
- Industrial gases
- Cryogenic applications
- District energy and building automation
- Metallurgy and mining
- Pulp and paper
- Water technology
- Other industries

PRODUCTS

- Valves
- Self-operated regulators
- Actuators
- Positioners and valve accessories
- Signal converters
- Controllers and automation systems
- Sensors and thermostats
- Digital solutions

SALES SITES

- More than 60 subsidiaries
in over 40 countries
- More than 200 representatives

PRODUCTION SITES

- SAMSON Germany, Frankfurt, established in 1916
Total plot and production area: 150,000 m²
- SAMSON France, Lyon, established in 1962
Total plot and production area: 23,400 m²
- SAMSON Turkey, Istanbul, established in 1984
Total plot and production area: 11,100 m²
- SAMSON USA, Baytown, TX, established in 1992
Total plot and production area: 20,000 m²
- SAMSON China, Beijing, established in 1998
Total plot and production area: 47,000 m²
- SAMSON India, Pune district, established in 1999
Total plot and production area: 28,000 m²
- SAMSON AIR TORQUE, Bergamo, Italy
Total plot and production area: 27,000 m²
- SAMSON CERA SYSTEM, Hermsdorf, Germany
Total plot and production area: 14,700 m²
- SAMSON KT-ELEKTRONIK, Berlin, Germany
Total plot and production area: 1,100 m²
- SAMSON LEUSCH, Neuss, Germany
Total plot and production area: 18,400 m²
- SAMSON PFEIFFER, Kempen, Germany
Total plot and production area: 20,300 m²
- SAMSON RINGO, Zaragoza, Spain
Total plot and production area: 19,000 m²
- SAMSON SED, Bad Rappenau, Germany
Total plot and production area: 10,400 m²
- SAMSON STARLINE, Bergamo, Italy
Total plot and production area: 27,000 m²
- SAMSON VDH PRODUCTS, the Netherlands
Total plot and production area: 12,000 m²
- SAMSON VETEC, Speyer, Germany
Total plot and production area: 27,100 m²

SAMSON AKTIENGESELLSCHAFT

Weismuellerstrasse 3 · 60314 Frankfurt am Main, Germany
Phone: +49 69 4009-0 · Fax: +49 69 4009-1507
E-mail: samson@samsongroup.com
Internet: www.samsongroup.com